

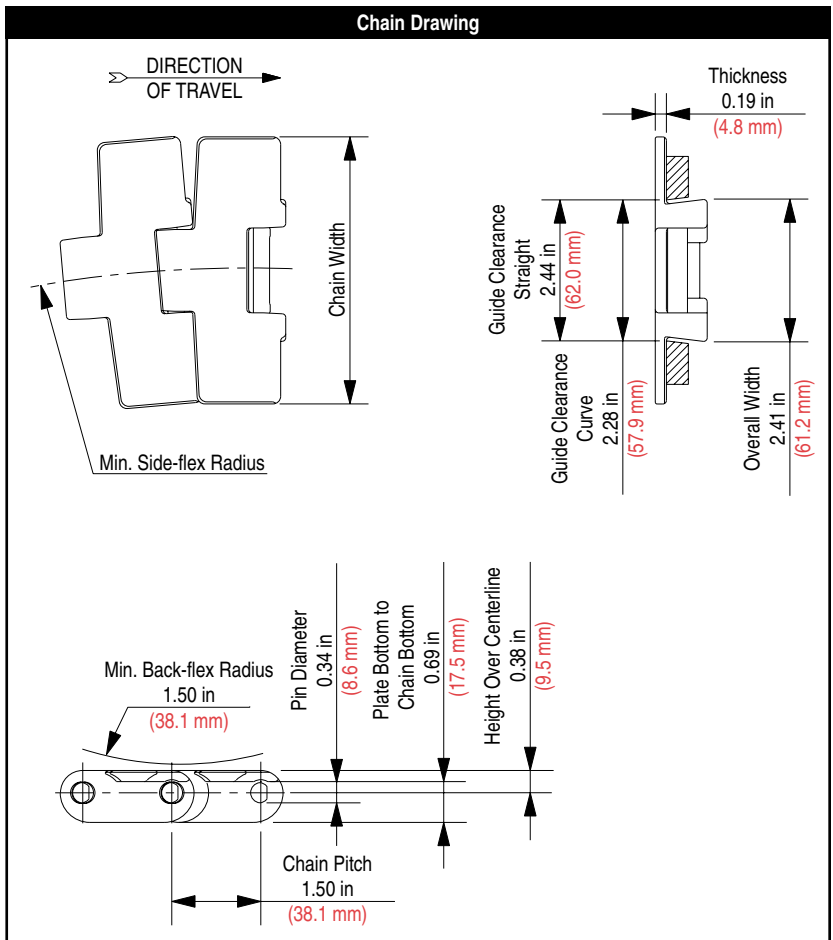

Chain is shown in Low Friction (LF) material.



Chain Information

desc	Chain Width		Min. Side-flex Radius		Approximate Weight	
	in	mm	in	mm	lbs/ft	kg/m
4-1/2	4.50	114.3	24.00	609.6	1.30	1.93
7-1/2	7.50	190.5	24.00	609.6	1.60	2.37
10	10.00	254.0	24.00	609.6	1.90	2.82

Available Materials

Prefix	Chain Material	Standard Pin Material	Temperature						Chain Strength		FDA Approval
			Fahrenheit			Celsius					
			min	max		min	max		lbs	N	
				dry	wet		dry	wet			
AS	Anti-Static	Stainless Steel	0	+180	+150	-18	+82	+66	375	1,668	-
CR	Extreme Chemical Resistant	Stainless Steel	+40	+250	+212	+4	+121	+100	500	2,224	✓
D	Plain Acetal	Stainless Steel	-40	+180	+150	-40	+82	+66	625	2,780	✓
WD	White Plain Acetal	Stainless Steel	-40	+180	+150	-40	+82	+66	625	2,780	✓
FR	Flame Retardant	Stainless Steel	0	+180	+140	-18	+82	+60	375	1,668	-
HP™	High Performance	Stainless Steel	-40	+180	+150	-40	+82	+66	625	2,780	✓
WHP	White High Performance	Stainless Steel	-40	+180	+150	-40	+82	+66	625	2,780	✓
LF	Low Friction	Stainless Steel	-40	+180	+150	-40	+82	+66	625	2,780	✓
WLF	White Low Friction	Stainless Steel	-40	+180	+150	-40	+82	+66	625	2,780	✓
MR	Melt Resistant	Stainless Steel	-80	+220	NR	-62	+104	NR	625	2,780	-
P	Chemical Resistant	Stainless Steel	0	+180	+140	-18	+82	+60	500	2,224	✓
DUV	Ultraviolet Resistant	Stainless Steel	0	+180	+150	-18	+82	+66	625	2,780	-
BWR	Black Wear Resistant	Stainless Steel	-40	+180	NR	-40	+82	NR	750	3,336	-

Standard materials are highlighted. All other materials are available on a made-to-order basis. Chain strength is listed at room temperature. NR = Not Recommended.

Regulatory Information

The Food and Drug Administration (FDA) accepts certain materials for direct food contact. FDA approved material is compliant to FDA 21 CFR § 177.

Rexnord, Rex, TableTop and HP are trademarks of Rexnord Corporation. All rights reserved.

Additional Notes

1. Stocked in 80 pitch, 10 ft (3.048 m) length strands.
2. Thermoplastic pins are available on a made-to-order basis.



Chain is shown in Low Friction (LF) material.

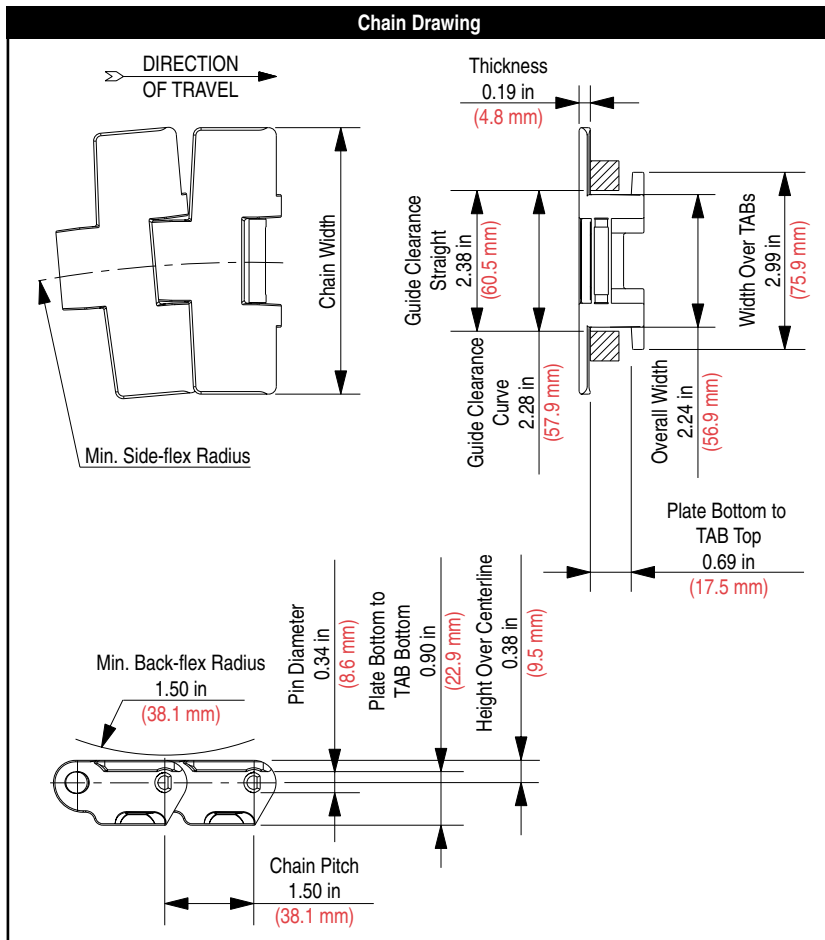

Chain Information						
Chain Width		Min. Side-flex Radius		Approximate Weight		
desc	in	mm	in	mm	lbs/ft	kg/m
3-1/4	3.25	82.6	24.00	609.6	1.25	1.85
4-1/2	4.50	114.3	24.00	609.6	1.33	1.97
7-1/2	7.50	190.5	24.00	609.6	1.63	2.42
10	10.00	254.0	24.00	609.6	1.90	2.82
12	12.00	304.8	24.00	609.6	2.13	3.16

Available Materials

Prefix	Chain Material	Standard Pin Material	Temperature						Chain Strength		FDA Approval
			Fahrenheit			Celsius					
			min	max		min	max				
				dry	wet		dry	wet			
AS	Anti-Static	Stainless Steel	0	+180	+150	-18	+82	+66	375	1,668	-
CR	Extreme Chemical Resistant	Stainless Steel	+40	+250	+212	+4	+121	+100	500	2,224	✓
D	Plain Acetal	Stainless Steel	-40	+180	+150	-40	+82	+66	625	2,780	✓
WD	White Plain Acetal	Stainless Steel	-40	+180	+150	-40	+82	+66	625	2,780	✓
FR	Flame Retardant	Stainless Steel	0	+180	+140	-18	+82	+60	375	1,668	-
HP™	High Performance	Stainless Steel	-40	+180	+150	-40	+82	+66	625	2,780	✓
WHP	White High Performance	Stainless Steel	-40	+180	+150	-40	+82	+66	625	2,780	✓
LF	Low Friction	Stainless Steel	-40	+180	+150	-40	+82	+66	625	2,780	✓
WLF	White Low Friction	Stainless Steel	-40	+180	+150	-40	+82	+66	625	2,780	✓
MR	Melt Resistant	Stainless Steel	-80	+220	NR	-62	+104	NR	625	2,780	-
P	Chemical Resistant	Stainless Steel	0	+180	+140	-18	+82	+60	500	2,224	✓
DUV	Ultraviolet Resistant	Stainless Steel	0	+180	+150	-18	+82	+66	625	2,780	-
BWR	Black Wear Resistant	Stainless Steel	-40	+180	NR	-40	+82	NR	750	3,336	-

Standard materials are highlighted. All other materials are available on a made-to-order basis. Chain strength is listed at room temperature. NR = Not Recommended.

Regulatory Information

The Food and Drug Administration (FDA) accepts certain materials for direct food contact. FDA approved material is compliant to FDA 21 CFR § 177.

Rexnord, Rex, TableTop and HP are trademarks of Rexnord Corporation. All rights reserved.

Additional Notes

1. Stocked in 80 pitch, 10 ft (3.048 m) length strands.
2. Thermoplastic pins are available on a made-to-order basis.

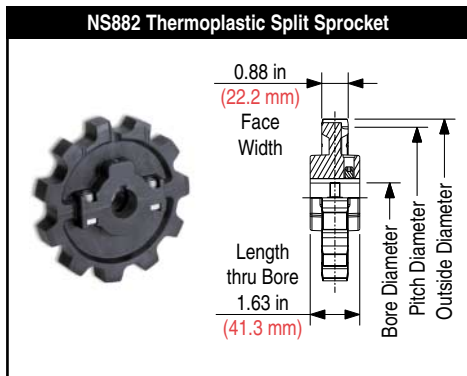
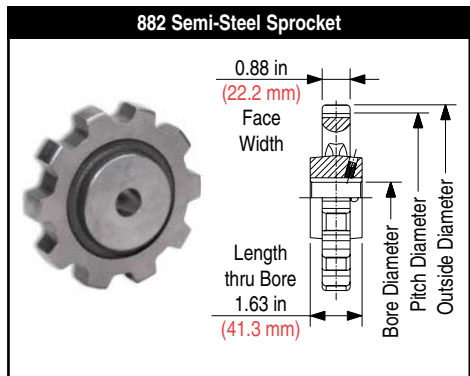

882 Semi-Steel Sprocket Information																			
Number of Teeth		Pitch Diameter		Outside Diameter		Bore Diameter (Shaft-Ready)								Bore Diameter (Round)				Approximate Weight	
						Round				Square				in		mm			
						in	mm	min	max	min	max	min	max	min	max	min	max		
actual	effect	in	mm	in	mm	min	max	min	max	min	max	min	max	min	max	min	max	lbs	kg
9	9	4.386	111.40	4.43	112.5	3/4	1-3/8	20	35	-	-	-	-	3/4	2-1/4	20	55	3.75	1.70
10	10	4.854	123.29	4.92	125.0	3/4	1-3/8	20	35	-	-	-	-	3/4	2-1/4	20	55	4.19	1.90
11	11	5.325	135.26	5.41	137.4	3/4	1-1/2	20	40	-	-	-	-	3/4	2-1/4	20	55	4.41	2.00
12	12	5.796	147.22	5.90	149.9	3/4	1-3/8	20	35	-	-	-	-	3/4	2-1/4	20	55	4.63	2.10
15	15	7.215	183.26	7.36	186.9	3/4	1-3/4	20	45	-	-	-	-	3/4	2-3/4	20	65	6.24	2.83

Shaft-ready round bores are shipped with keyway and setscrews. Metric shaft-ready round bores are shipped with metric hardware, but without setscrews.

NS882 Thermoplastic Split Sprocket Information																			
Number of Teeth		Pitch Diameter		Outside Diameter		Bore Diameter (Shaft-Ready)								Bore Diameter (Idler)				Approximate Weight	
						Round				Square				in		mm			
						in	mm	min	max	min	max	min	max	min	max	min	max		
actual	effect	in	mm	in	mm	min	max	min	max	min	max	min	max	min	max	min	max	lbs	kg
11	11	5.325	135.26	5.41	137.4	1	1-3/4	25	45	-	-	-	-	1	1-3/4	25	45	0.66	0.30
12	12	5.796	147.22	5.90	149.9	1	1-3/8	25	35	-	-	-	-	1	1-3/4	25	45	0.82	0.37

Shaft-ready round bores are shipped with keyway and setscrews. Metric shaft-ready round bores are shipped with metric hardware, but without setscrews. Idler bores are designed to spin freely on the shaft without keyway or setscrews.

Corner Track (One Piece)

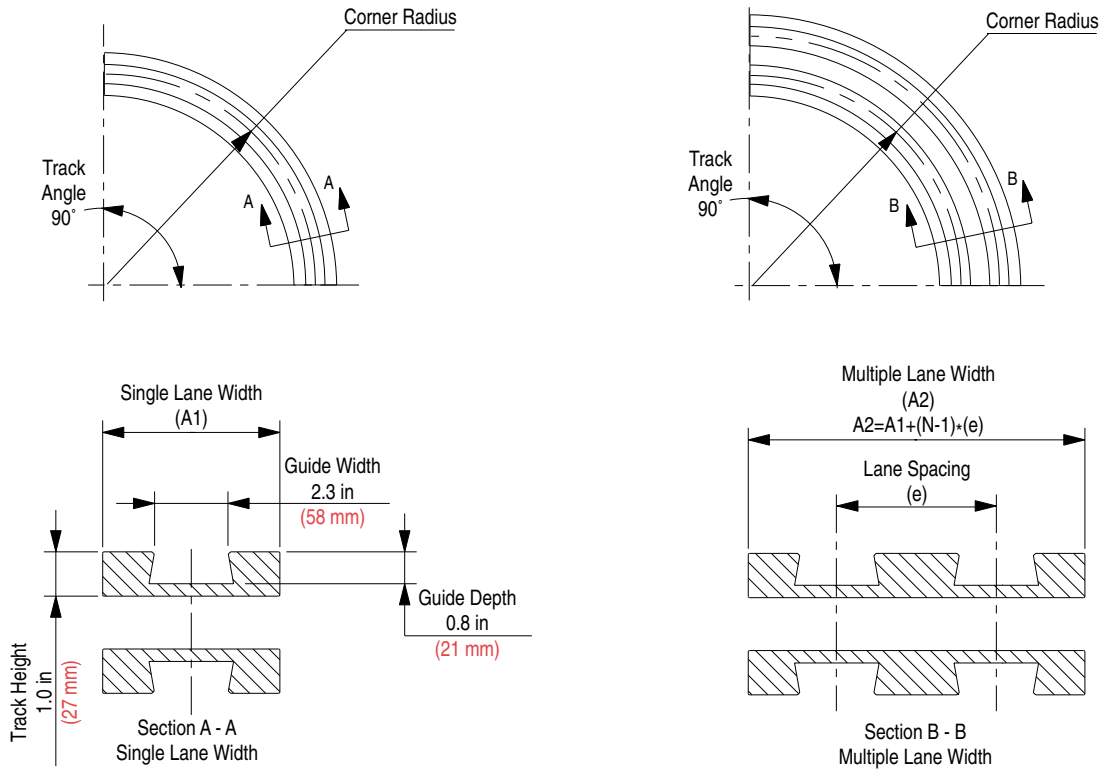

Corner track number supplied as one 90° inside and one 90° outside track, which can be used as either carry or return.

All one piece corner tracks are available on a made-to-order basis.

For 882 (bevel) chain only. Do not use with 882 TAB chains.

Corner Track Number	Chain Width		Corner Radius		Single Lane Width (A1)		Multiple Lane Width (A2)		Lane Spacing (e)		Material	Color	Number of Lanes (N)	Approximate Weight	
	in	mm	in	mm	in	mm	in	mm	in	mm				lbs	kg
KSU218610-1	4-1/2	114.3	24.0	610	4.9	125	-	-	4.7	120	UHMWPE	Black	1	16.48	7.48
KSU218610-2							9.7	245					2	32.32	14.66
KSU218610-3							14.4	365					3	48.13	21.83
KSU218610-4							19.1	485					4	63.94	29.00
KSU230610-1	7-1/2	190.5	24.0	610	7.9	200	-	-	7.7	195			1	26.36	11.96
KSU230610-2							15.6	395					2	52.08	23.62
KSU230762-1			30.0	762			-	-					1	32.95	14.95
KSU230762-2							15.6	395					2	65.10	29.53
KSU240610-1	10	254.0	24.0	610	10.4	265	-	-	10.2	260			1	34.93	15.84
KSU240762-1			30.0	762			1	43.67					19.81		

Corner Track (One Piece)

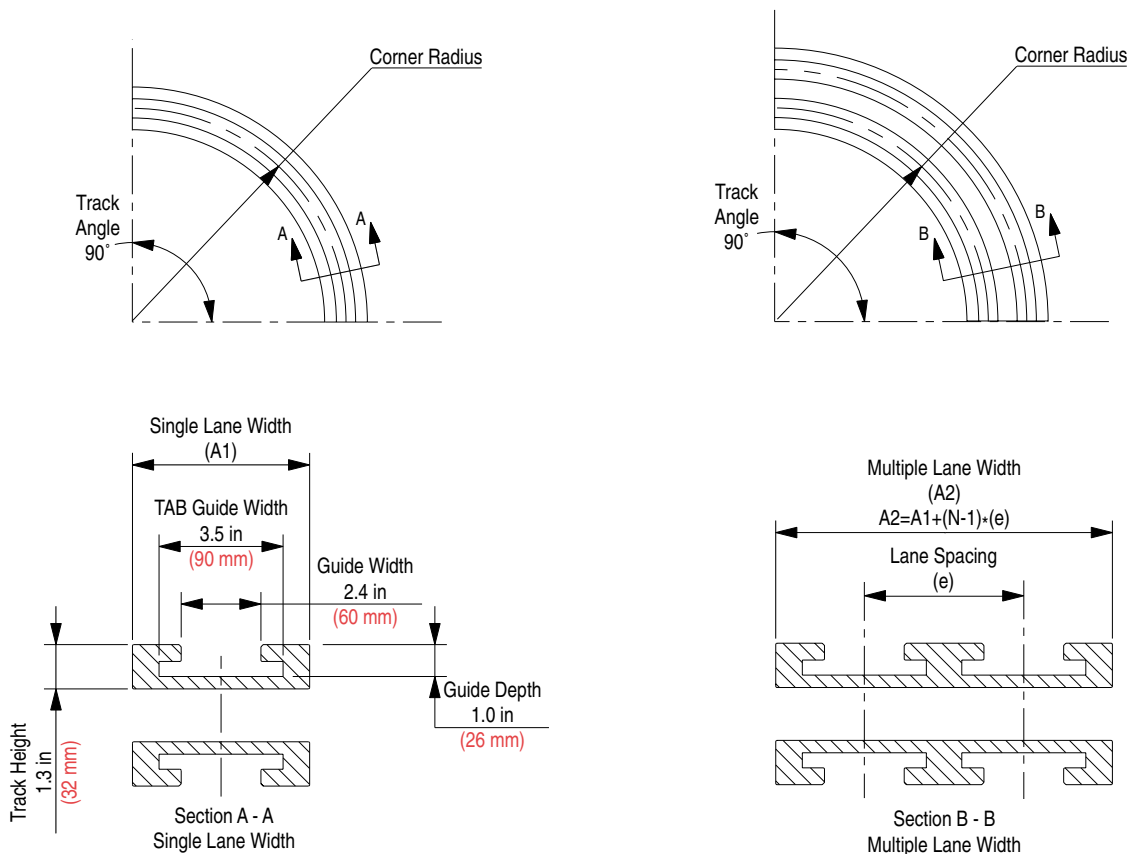

Corner track number supplied as one 90° inside and one 90° outside track, which can be used as either carry or return.

All one piece corner tracks are available on a made-to-order basis.

For 882 TAB chains only. Do not use with 882 (bevel) chains.

Corner Track Number	Chain Width		Corner Radius		Single Lane Width (A1)		Multiple Lane Width (A2)		Lane Spacing (e)		Material	Color	Number of Lanes (N)	Approximate Weight	
	in	mm	in	mm	in	mm	in	mm	in	mm				lbs	kg
KTU218610-1	4-1/2	114.3	24.0	610	4.9	125	-	-	4.7	120	UHMWPE	Black	1	19.59	8.89
KTU218610-2							9.7	245					2	38.42	17.43
KTU218610-3							14.4	365					3	57.21	25.95
KTU218610-4							19.1	485					4	76.00	34.47
KTU230610-1	7-1/2	190.5	24.0	610	7.9	200	-	-	7.7	195			1	31.33	14.21
KTU230610-2							15.6	395					2	61.91	28.08
KTU230762-1			30.0	762			-	-					1	39.17	17.77
KTU230762-2							15.6	395					2	77.39	35.10
KTU240610-1	10	254.0	24.0	610	10.4	265	-	-	10.2	260			1	41.53	18.84
KTU240762-1			30.0	762			1	51.91					23.55		
KTU248610-1	12	304.8	24.0	610	12.6	320	-	-	12.2	310			1	50.16	22.75
KTU248762-1			30.0	762			1	62.71					28.44		

Corner Track (Two Piece)

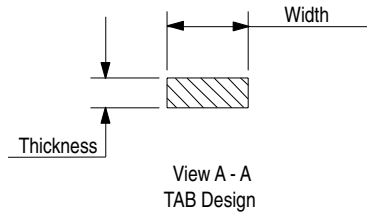
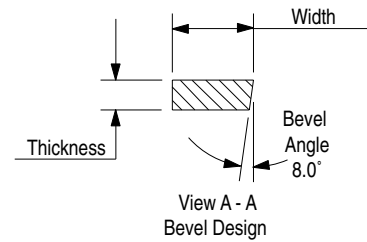
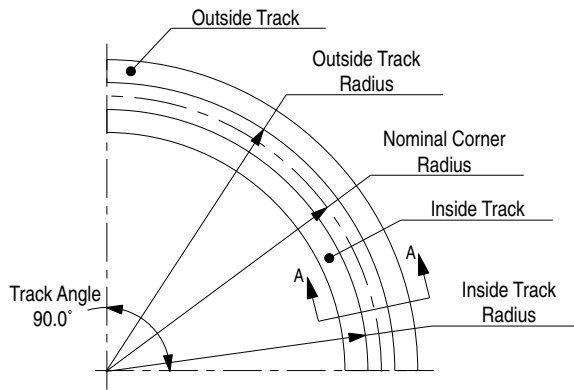

Corner track number supplied as one 90° inside and one 90° outside track, which can be used as either carry or return.

Corner Track Number	Accommodates Top Plate Width		Nominal Corner Radius		Inside Track Radius		Outside Track Radius		Thickness		Width		Material	Color	Approximate Weight	
	in	mm	in	mm	in	mm	in	mm	in	mm	in	mm			lbs	kg
Bevel Design																
N24B5	All	All	24.0	610	22.9	582	25.1	638	0.6	16	1.5	38	Nylatron®	Black	2.89	1.31
TAB Design																
N24R5	All	All	24.0	610	22.9	582	25.1	638	0.6	16	1.5	38	Nylatron®	Black	2.89	1.31

Nylatron is a registered trademark of Polymer Corporation.

Corner Track (Four Piece)

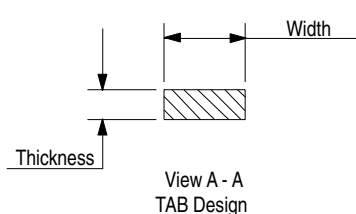
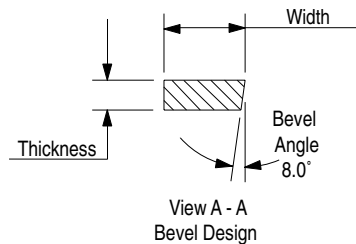
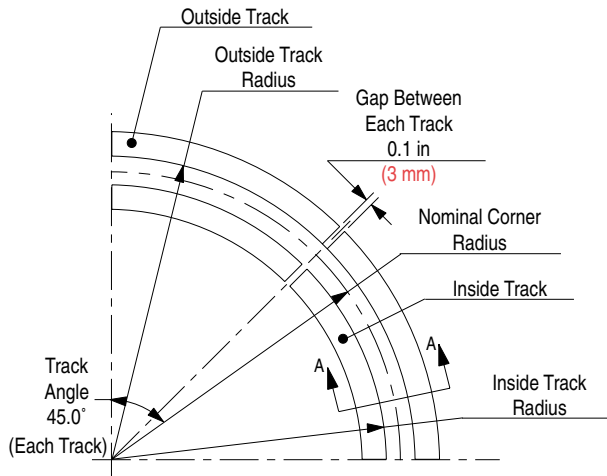

30 in (762 mm) radius furnished in two 45° segments to make one 90° unit.

Corner track number supplied as two 45° inside tracks and two 45° outside tracks, which can be used as either carry or return.

Corner Track Number	Accommodates Top Plate Width		Nominal Corner Radius		Inside Track Radius		Outside Track Radius		Thickness		Width		Material	Color	Approximate Weight	
	in	mm	in	mm	in	mm	in	mm	in	mm	in	mm			lbs	kg
Bevel Design																
N30B5	All	All	30.0	762	28.9	734	31.1	790	0.6	16	1.5	38	Nylatron®	Black	3.61	1.64
TAB Design																
N30R5	All	All	30.0	762	28.9	734	31.1	790	0.6	16	1.5	38	Nylatron®	Black	3.61	1.64

Nylatron is a registered trademark of Polymer Corporation.

Pusher Attachment (F-Style)

All pusher attachments are molded 12 in (304.8 mm) wide and can be cut down to a minimum height of 1/4 in (6.35 mm). Pusher attachment width can be cut to match chain width.

The F2 designation represents an F-style pusher attachment at a height of 2 in (50.8 mm). For 882 TAB chain only.

Please indicate if pusher attachments are required every pitch, every second pitch, etc. when ordering. Also, indicate if indents are required in the center, on one or both sides of the chain.

For example, "I would like F2 pusher attachments every 8th pitch indented 3/4 in on both sides of the chain."

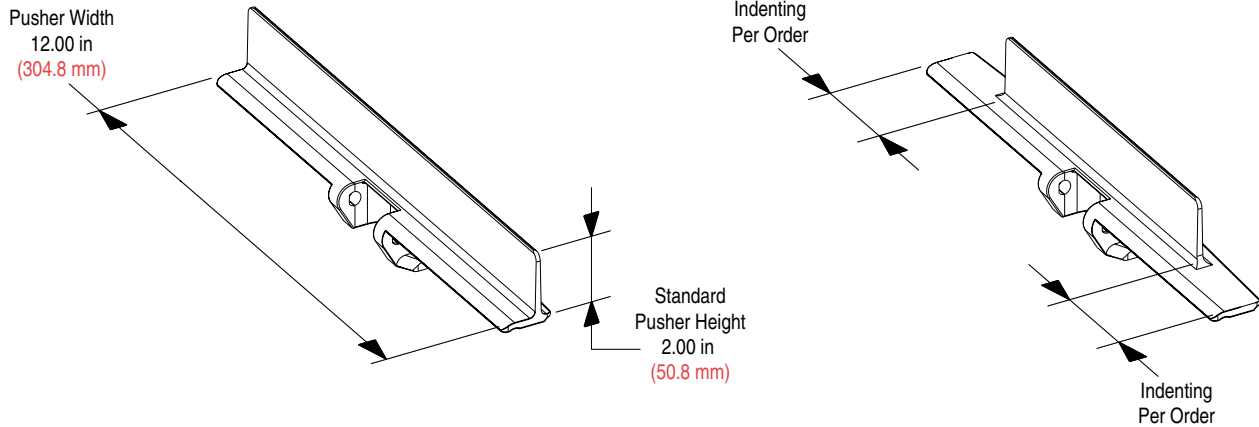

Gripper Attachments

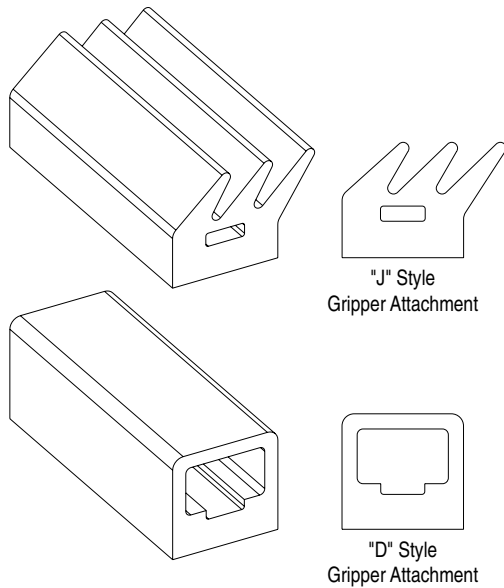

Part Number	Style	Material	Color	Hardness (Shore A)
114-582-1	D	Neoprene	Black	40
114-582-2	D	Neoprene	White	50
114-582-3	D	Neoprene	White	40
114-582-4	D	Neoprene	Black	60
114-1625-1	D (Thick Wall)	Neoprene	White	40
114-582-5	D	EPDM	White	50
114-582-6	D	EPDM	White	80
114-582-7	D	EPDM	Black	50
114-647-1	J	Neoprene	Black	40
114-647-2	J	Neoprene	White	50
114-647-3	J	Neoprene	White	40
114-647-4	J	EPDM	White	80
114-647-5	J	EPDM	White	50