

Corner Disc (Flat Top)

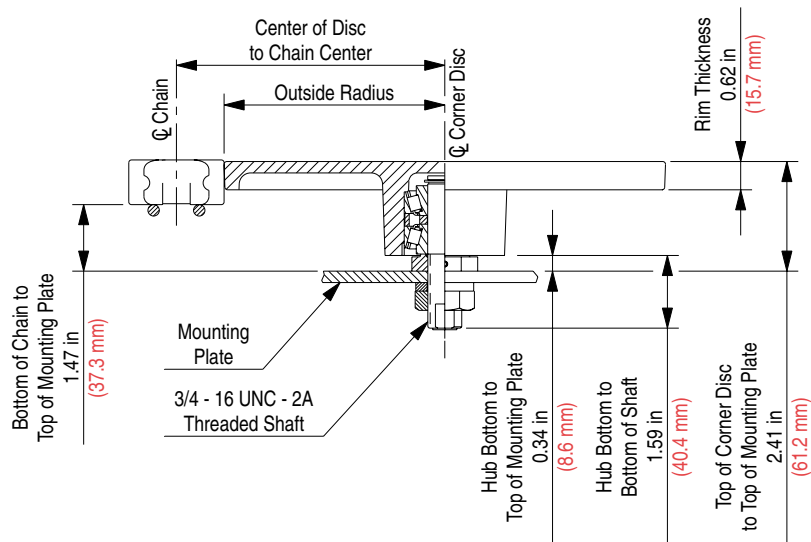

Corner Disc Number	Center of Disc to Chain Center		Outside Radius		Approximate Weight	
	in	mm	in	mm	lbs	kg
1702 FT-10	5.90	150.0	4.86	123.4	4.20	1.91
1702 FT-18	10.00	254.0	8.94	227.1	7.00	3.18

Corner Disc Material: Aluminum

Corner Disc (Raised Hub)

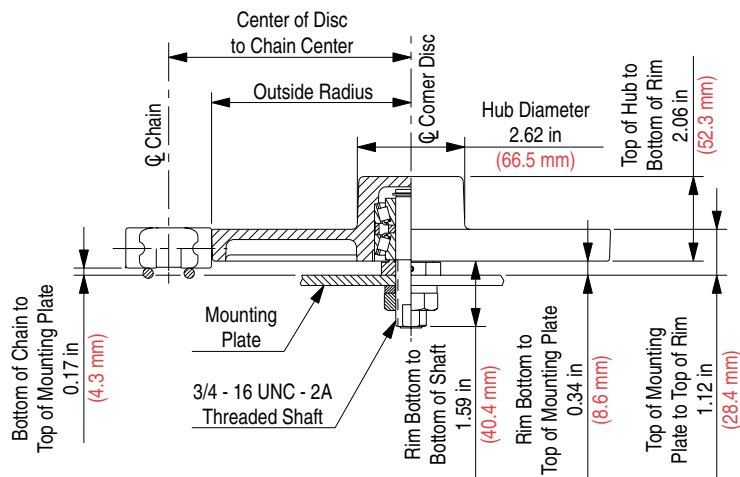

Corner Disc Number	Center of Disc to Chain Center		Outside Radius		Approximate Weight	
	in	mm	in	mm	lbs	kg
1702 RH-10	5.90	150.0	4.86	123.4	4.20	1.91

Corner Disc Material: Aluminum

Extended Pivot

Please indicate if you require an extended pivot every pitch, every second pitch, etc. when ordering.

