

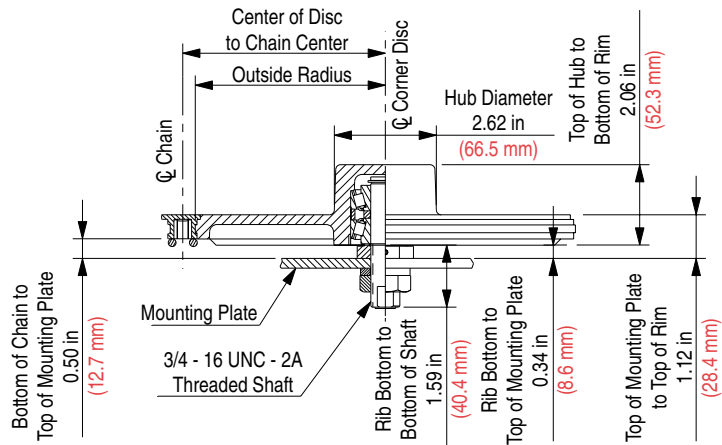



Corner Disc (Raised Hub)



Corner Disc Number	Center of Disc to Chain Center		Outside Radius		Approximate Weight	
	in	mm	in	mm	lbs	kg
1755 RH-10	5.40	137.2	4.88	124.0	4.20	1.91

Corner Disc Material: Aluminum