

Corner Disc (Raised Hub)

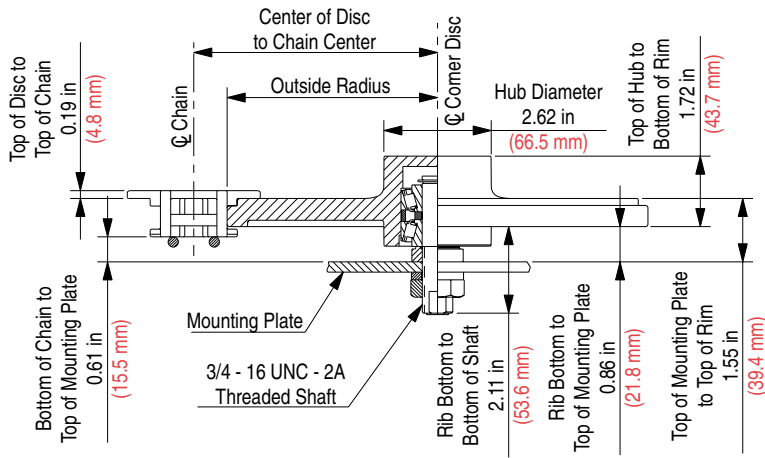

Corner Disc Number	Center of Disc to Chain Center		Outside Radius		Approximate Weight	
	in	mm	in	mm	lbs	kg
1757 RH-10	6.00	152.4	5.12	130.0	4.20	1.91

Corner Disc Material: Aluminum

Pusher Attachment (F-Style)

The F3 designation represents an F-style pusher attachment at a height of 3 in (76.2 mm).

Please indicate if pusher attachments are required every pitch, every second pitch, etc. when ordering.

For example, "I would like F3 pusher attachments every 8th pitch".

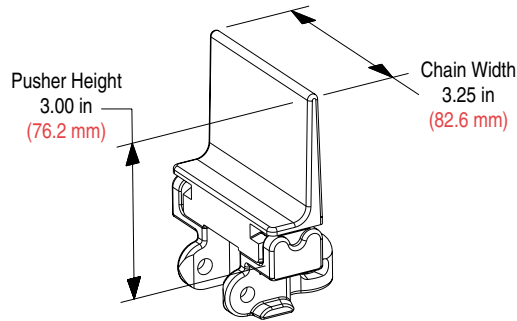

Pusher Attachment (Finger Style)

Please indicate if pusher attachments are required every pitch, every second pitch, etc. when ordering.

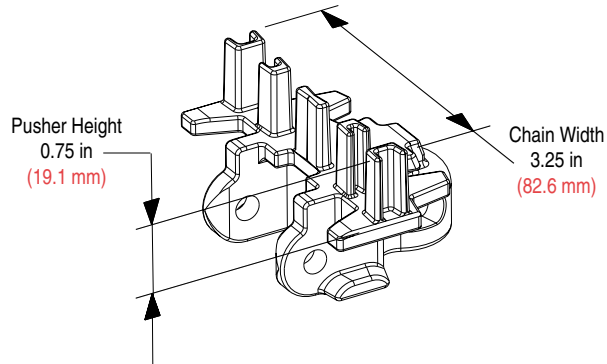

Gripper Attachments

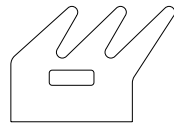
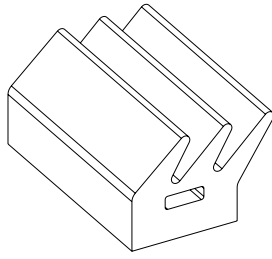

"J" Style
Gripper Attachment

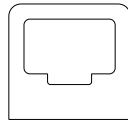
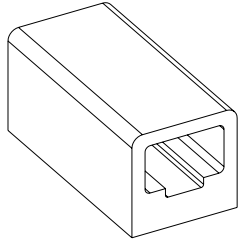

"D" Style
Gripper Attachment

Part Number	Style	Material	Color	Hardness (Shore A)
114-2644-1	D	Neoprene	Black	40
114-2644-2	D	Neoprene	White	50
114-2644-3	D	Neoprene	White	40
114-2644-4	D	Neoprene	Black	60
114-2644-5	D	EPDM	White	50
114-2644-6	D	EPDM	White	80
114-2644-7	D	EPDM	Black	50
114-2644-8	D	Neoprene	White	50
114-2700-1	J	Neoprene	Black	40
114-2700-2	J	Neoprene	White	50
114-2700-3	J	Neoprene	White	40
114-2700-4	J	EPDM	White	80
114-2700-5	J	EPDM	White	50