

Corner Disc (Flat Top)

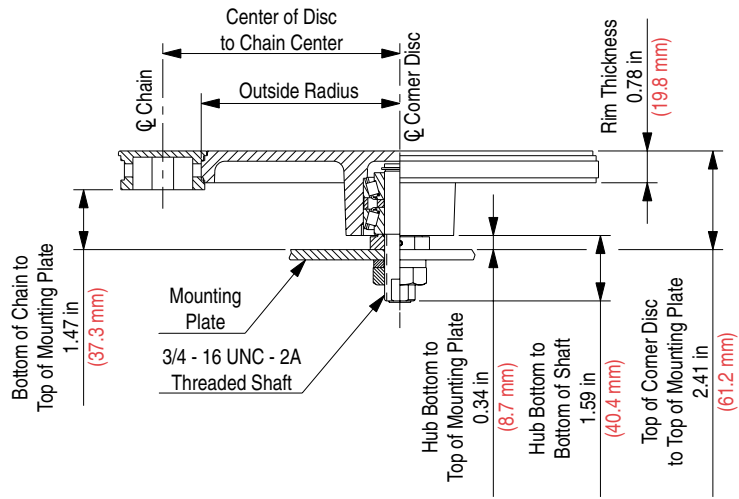

Corner Disc Number	Center of Disc to Chain Center		Outside Radius		Approximate Weight	
	in	mm	in	mm	lbs	kg
1700 FT-10	5.90	150.0	4.84	123.0	4.20	1.91
1700 FT-18	10.00	254.0	8.94	227.1	7.00	3.18

Corner Disc Material: Aluminum

Corner Disc (Raised Hub)

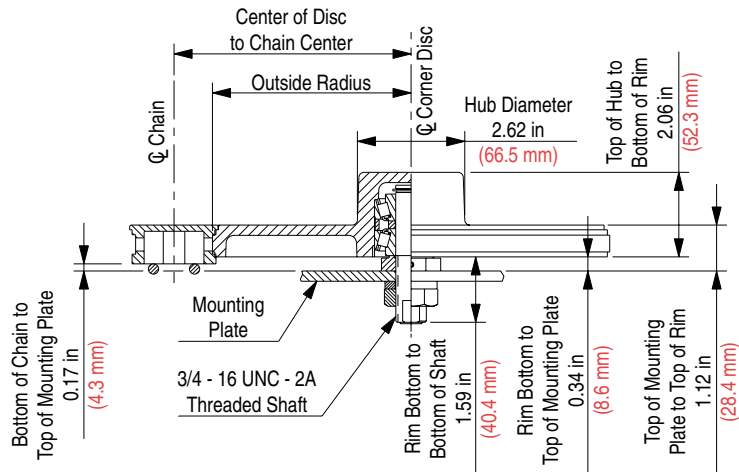

Corner Disc Number	Center of Disc to Chain Center		Outside Radius		Approximate Weight	
	in	mm	in	mm	lbs	kg
1700 RH-10	5.90	150.0	4.84	123.0	4.20	1.91

Corner Disc Material: Aluminum