

■ DESIGN AND SELECTION

SELECTION OF CHAINS

The following sections of this catalog are devoted to presenting comprehensive selection procedures for drive, conveyor, and elevator chains. The information included provides economical selections, yet assures the correct choice of components which can withstand the rigors of the application. Because there is an almost unlimited variety of component applications, these selections are meant only to serve as a guide when designing new systems. On existing installations, the selection guides will prove helpful in determining whether a component in use is the most economical choice. They will also serve to guide the upgrading of present installations where service life is not satisfactory.

Rexnord Selection Services

Rexnord application engineers are available to assist in the selection of chains and components. Gather all pertinent technical information regarding the application, and call us at (414) 643-3000 or fax us at (414) 643-2609.

Chain Ratings

As a result of extensive testing and field experience, load ratings have been established for **drive** chains based on **wear durability** and **fatigue strength** to provide 15,000 hours chain life under the ideal conditions of clean environment, proper installation, maintenance, and lubrication. Drive chains are selected in the tables by horsepower and speed.

All other types of metal chains should be selected based on working load and chain speed limitations, with due regard for experience in similar application environments. A chain's working load is the maximum load (chain pull) a chain can withstand without a shortened life due to accelerated wear or breakage. Polymeric (non-metallic) chains have unique selection considerations which are covered in the Polymeric section of this catalog.

Rex® and Link-Belt® chains are also rated according to the Standards and Policies and Procedure Recordings of the American Chain Association. Most notably, we publish a **minimum ultimate tensile strength (MUTS)**. This represents the minimum force at which an unused, undamaged chain could fail when subjected to a single tensile loading test.

It should be noted that chains **should not** be selected based on ultimate strength ratings. Design considerations chosen to maximize ultimate strengths frequently are not consistent with obtaining the best possible resistance to the modes of failure that most often limit a chain's life (e.g. low-cycle fatigue, corrosion induced embrittlement, etc.). Chains that sacrifice some degree of tensile strength to obtain greater ductility, toughness, and resistance to embrittling conditions are far better suited to most application environments.

DRIVE CHAIN SELECTION

Rex and Link-Belt drive chains of all steel construction are ruggedly built, dependable chains for service in the **slow to moderate speed ranges and heavy loads**. Since they operate over cast sprockets with hardened teeth or fabricated steel sprockets, and are long in pitch compared to ANSI roller chain, **they are a more economical choice than other chains**.

Under exposed conditions, or where dust and dirt are present, the designed, built-in clearance between the working parts of our drive chains make them very suitable for service. Conveyor and elevator drives are ideal for Rex and Link-Belt drive chains since they **withstand heavy shock loads and exposed operating conditions**.

Rexnord's 3100 Series of steel chain is designed to have advantages and features of our other steel chains and to be a replacement for ANSI roller chains.

Rex and Link-Belt drive chains are not designed for attachments. See pages 10 to 29 for chains with attachments.

GENERAL DESIGN CONSIDERATIONS

Basis for Selection

Selections are based on laboratory tested and field proven horsepower capacity and speed data rather than "working loads." The horsepower capacity ratings have been developed on the basis of fatigue strength and wear capacity of the chain components. Under ideal conditions of clean environment, proper installation, maintenance, and lubrication, the selections listed are intended to provide 15,000 hours chain life for 100 pitch strands.

More economical chain selections are available. For applications where a chain life of less than 15,000 hours is acceptable, contact your Rexnord representative.

Economy

When selecting a chain drive, consider all elements, but use only those that are required for the safe and successful operation of the drive application.

In evaluating the economy of a chain-sprocket drive system, consider the overall cost of the chain and sprockets in the system and not merely the cost per foot of chain.

Chain

The best chain and sprocket combination is selected in the **12-tooth** column. Occasionally, the same chain will appear under the three sprocket selections; that is 9T, 12T, and 15T. This same chain is the most **economical** choice of all the other chains that were considered.

Selection for 9-tooth sprockets are limited, in some cases, by commercial steel shafting. Where alloy shafting is required, see Rexnord for recommendations.

DESIGN AND SELECTION

SPROCKETS

Rex® sprockets are designed with full attention to the requirements for proper chain-sprocket interaction. For each size and type of sprocket, Rexnord Engineers have selected the proper tooth pressure angle, pitch-line-clearance, bottom diameter and tooth pocket radius for maximum service.

Fabricated steel sprockets are recommended as the preferred choice for all chain drives. Cast sprockets with hardened teeth are also available for use on slower drives.

Largest Keyseated Bore

The “largest keyseated bore” shown in the drive chain selection tables (pages 110-118), indicates the largest shaft that may be used with the sprocket hub selected. Sprocket hubs will deliver the HP and RPM used for the selection but are not designed for the torque that could be delivered by the largest keyseated shaft shown in the table.

If a larger bore than shown is required, select a larger sprocket. The largest bore is selected from the hub size table for the material shown, either Cast Sprockets with hardened teeth or Fabricated Steel, and defines the largest hub diameter which will fit without interfering with the chain.

Chain Slack

For best operating service, allow a sag in the slack strand equal to 3% of sprocket centers.

DRIVE ARRANGEMENTS

Relative position of sprockets in drives should receive careful consideration. Satisfactory operation can be secured with the centerline of the drive at any angle to the horizontal, if proper consideration is given. Certain arrangements require less attention and care than others are, therefore, less apt to cause trouble. Various arrangements are illustrated in the diagrams. The direction of rotation of the drive sprocket is indicated.

Best Arrangements

Arrangements considered good practice are illustrated in Figs. 1, 2, 3, and 4. The direction of rotation of the drive sprockets in Figs. 1 and 4 can be reversed.

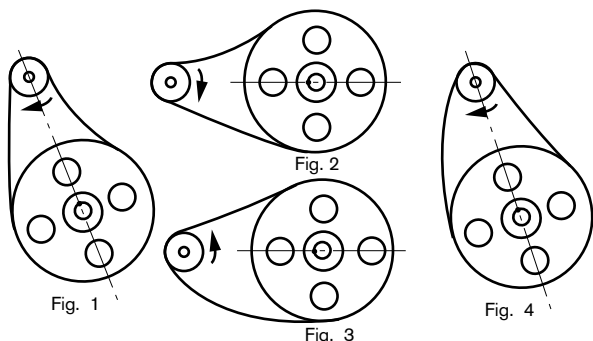

Other Acceptable Arrangements

If none of the above arrangements can be followed, an attempt should be made to use an arrangement as illustrated in Figs. 5, 6, and 7.

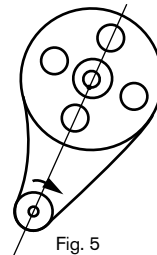

Fig. 5

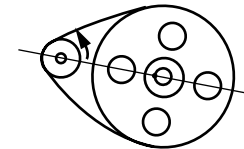

Fig. 6

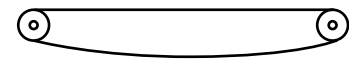

Fig. 7

When the large sprocket is directly above the small sprocket, Fig. 8, a drive cannot operate with much chain slack. As the chain wears, shaft-center distance must be adjusted or an idler be placed against the outside of the slack strand (near the small sprocket) to adjust slack and keep the chain in proper contact with the small sprocket.

With the drive slightly inclined, Fig. 5, less care will be required, because the weight of the slack chain strand helps to maintain better contact between the chain and the sprockets.

Where center distances are short, or drives nearly horizontal, the slack should be in the bottom strand, especially where take-up adjustment is limited, Fig. 6 rather than Fig. 9. An accumulation of slack in the top strand may allow the chain to be pinched between the sprockets, Fig. 9.

When small sprockets are used on horizontal drives, it is better to have the slack strand on the bottom, Fig. 7, rather than on the top, Fig. 10. Otherwise, with the appreciable amount of slack, the strands may strike each other.

Least Recommended Arrangements

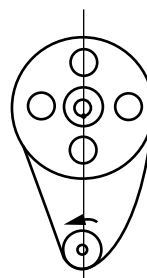

Fig. 8

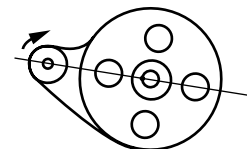

Fig. 9



Fig. 10

DESIGN AND SELECTION

DRIVE CHAIN SELECTION

Selecting a Chain Using Selection Tables

Step 1. Determine Horsepower... Motor or actual.

Step 2. Select Service Factor (SF)...

See Table 1, pages 108-109.

Step 3. Calculate Design Horsepower (DHP).

$$DHP = SF \times HP$$

Step 4. Determine Speed... Drive Shaft RPM.

Step 5. Select the chains in the 12T. column from

Table 2, pages 110-118.

Example: 20 HP; 70 RPM; 1.25 SF: (DHP = HP)

RPM Driver Sprocket	25 DHP						Type of Lub
	Driver Sprocket – No. of Teeth – Hub Size Letter						
	9T		12T		15T		
80-90	R1037	3 ^{3/16}	1030	5 ^{15/16}	R3112	4 ^{15/16}	I
			3160	3 ^{3/16}	3160	4 ^{7/16}	
70-80	R1037	3 ^{3/16}	1030	5 ^{15/16}	R514	5 ^{15/16}	I
			3180	3 ^{11/16}	3160	4 ^{7/16}	
60-70	R1037	3 ^{15/16}	R1033	5 ^{15/16}	1030	7	J
			3180	3 ^{11/16}	3160	4 ^{7/16}	

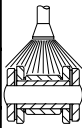

Note: If the RPM appears in two rows in the RPM column of the Selection Table (i.e. 70 RPM appears in 60-70 and 70-80 RPM rows) use the faster speed range for greatest economy. Also, see Step 6 for alternate selection.

12-Tooth Sprocket Selection Advantages

1. Most economical “Power Package” of chain and sprockets.
2. Quiet operation.
3. Increased wear life – approximately 70% greater chain wear life than a 9-tooth selection.
4. Best for space available and system economy.
5. Offers large speed ratio possibilities.

Step 6. Choose the proper drive... When an alternative is listed for a given selection (i.e. 3100 Series Chain is listed) choose the better drive based on the following considerations:

- Cost** – Evaluate the total cost of each drive package: chain and sprockets.
- Space Limitations** – The smaller pitch chain (usually 3100 Series) should provide the drive requirements in less space.
- Availability** – If delivery is crucial, consult Rexnord to see which of the two chains is more readily available.
- ANSI Replacement** – The 3100 Series Chains replace corresponding ANSI roller chains up to 350 RPM. This series chain operates over the same sprockets.
- Shaft Size** – The larger pitch chain of the

two will probably have to be used when the driver shaft size exceeds the maximum bore listed for the smaller chain.

f. Noise – Smaller pitch chain operating over cut tooth sprockets will provide quieter and smoother operation.

Step 7. For alternates to the 12-Tooth Sprocket Selection, see the 9- or 15-Tooth Sprocket Selections.

Check:

Space – Will sprocket and chain fit in the allowable space? For pitch diameter, see table on page 139.

Generally minimum space required for chain and sprocket = 1.2 x Pitch Diameter.

$$\text{Speed Ratio} = \frac{\text{Drive R Shaft RPM}}{\text{Drive N Shaft RPM}}$$

Availability – Is Drive N sprocket available for required speed ratio?

Select a 9T Sprocket where greater speed ratios and minimum space are required. The majority of 9-tooth selections will result in a space advantage.

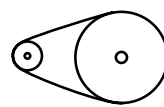
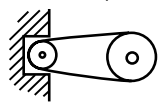
9-Tooth Sprocket Selection	
Advantages	Limitations
<ol style="list-style-type: none"> 1.  Greater Speed Ratios 2.  Generally, require less space than the 12T sprocket selection 	<ol style="list-style-type: none"> 1. Generally higher cost 2. Greater noise 3. Maximum wear 4. Less smooth running, more pulsations. (See Chordal Action Table on next page.)

Select a 15T Sprocket where long centers are necessary and space is not a limiting factor...

where maximum speed ratios are not required... or where quiet operation is desired.

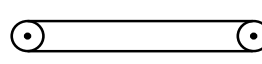
15-Tooth Sprocket Selection	
Advantages	Limitations
 <ol style="list-style-type: none"> 1. Most economical for long centers. 2. Least wear – approximately 150% greater chain wear life than the 9T. selection. 3. Least noise. 	<ol style="list-style-type: none"> 1. More space required. 2. Fewer speed ratio possibilities. 3. More costly than minimum center distances. 4. More chain required in the system.

DESIGN AND SELECTION

Step 8. Determine number of teeth on the DriveN sprocket, minimum center distance and chain length.

- Multiply number of teeth on DriveR by desired speed ratio (Step 7) to determine number of teeth on DriveN sprocket.
- Refer to pages 140-141 for minimum center distance and chain length calculations.

Step 9. Select DriveR and DriveN Sprocket Hubs and Material.

a. DriveR Sprocket and Hub

The sprocket hub size letter in the selection table identifies the minimum "Torque Rated" hub that will transmit the desired horsepower. Refer to the example shown in Step 5 on page 105. For this example, the hub is specified as letter I. The table on page 81 recommends a hub size of 4.5" by 2.0" (for a solid sprocket). The table also identifies the torque being transmitted, in this case up to 23,000 in-lbs. The hub size and bore diameter listed are recommended based on the limitations of the typical shaft material having a maximum torsion shear stress of 6,000 psi. If the shaft has already been determined, use the bore size column to select the appropriate hub dimensions.

Note: Fabricated steel sprockets with induction hardened teeth are the recommended first choice for drive applications but, if a cast sprocket is desired, be sure to check availability of the cast pattern as listed beginning on page 83. If the sprocket unit number is not listed, a pattern is not available. The table gives stocked hub dimensions. **Cast to order** sprocket hubs would be sized per page 81.

b. DriveN Sprocket and Hub

The proper DriveN sprocket hub can be determined from the following:

$$\text{Driven Hub Torque} = \text{Speed Ratio} \times \text{Driver Hub Torque}$$

The speed ratio and driver torque were determined in Step 8b and Step 9a. The DriveN sprocket hub is selected based on the driven hub torque and using the tables on page 81.

Referring to the example above, the driver hub was size I and the torque transmitted was 23,000 in-lbs. If the speed ratio were 2 to 1, we would be transmitting 46,000 in.-lbs. and would require a size L hub, (5.25 by 3) or larger.

c. Largest Keyseated Bore

The "Largest Keyseated Bore" next to each chain selection indicates the largest shaft that can be used with the sprocket, sprocket material, and hub size letter selected.

Step 10. Use the recommended lubrication method as shown in Table 2, pages 110-118. For the recommended lubricant, see page 135.

Note: For example of selection, see page 107.

Chordal Action

The rise and fall of each pitch of chain as it engages a sprocket is termed "chordal action" and causes repeated chain speed variations (pulsations). As illustrated by the chart below, chordal action and speed variation decreases as the number of teeth in the small sprocket is increased, and becomes negligible when 21 or more teeth are used. For example, the variation between minimum and maximum chain speed due to chordal action is 13% for a 6-tooth sprocket, 4% for an 11-tooth sprocket, and 1% for a 21-tooth sprocket. Where smooth operation is essential, use as many teeth as possible in the small sprocket.

Variation in Chain Speed Due to Chordal Action

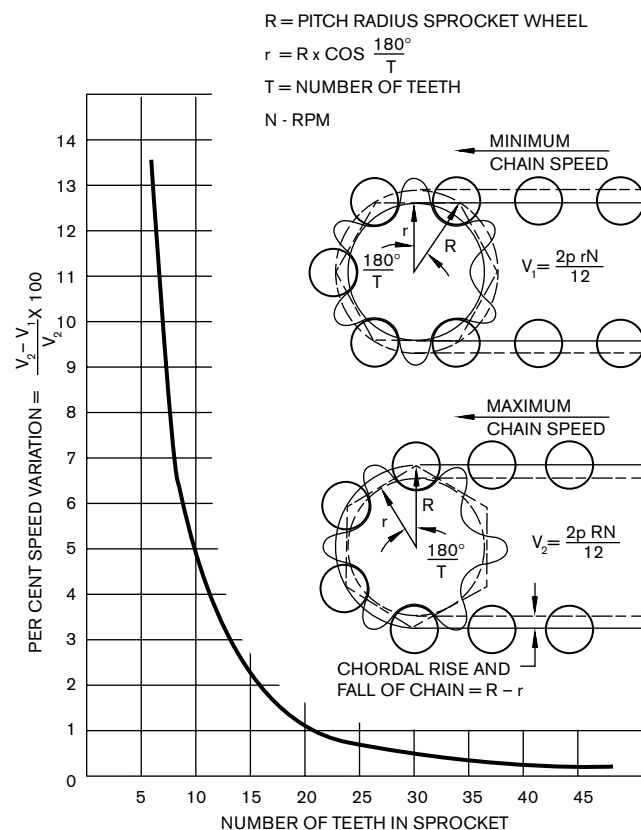

■ DESIGN AND SELECTION

DRIVE CHAIN SELECTION

Selecting a Chain Using Selection Tables

Drive Chain Selection Example:

A single roll rock crusher is to be operated at 44 RPM driven by a 50 HP engine. The speed reducer has an output shaft of 3.94", operating at 90 RPM. The crusher shaft is 5.94". The crusher will operate 8 hours per day. DriveR sprocket space restriction is 16".

Step 1. Horsepower

Motor or actual: 50 HP

Step 2. Service Factor

Type of Application: Crusher

Service Factor: (See Table 1 and "Converted Service Factor" chart on page 108.)

10 HR, Motor drive = 1.75 SF

10 HR, Engine driven = 2.0 SF

Step 3. Design Horsepower

DHP = 50 HP x 2.0 SF = 100 DHP

Step 4. Speed and Shaft Size

Speed and diameter of DriveR shaft:
90 RPM; 3.94"

Speed and diameter of DriveN shaft:
44 RPM; 6.94"

Step 5. Drive Chain and Driver Sprocket

A chain is selected for a 12-tooth DriveR sprocket at 100 DHP, 90 RPM (see Table 2 for selection).

RX238 Chain; 12-tooth DriveR Sprocket

Step 6. Choice of Drives

A choice must be made between two drives when both appear. However, at this rating, there is only one chain available – RX238.

Step 7. Space and Speed Ratio

Check space available for DriveR sprocket:

Using the pitch diameter table on page 140 –

a. A 12-tooth sprocket has a pitch diameter equivalent to 3.8637 pitches. The diameter in inches would be 3.8637 x the pitch (3.5" for RX238) = 13.52".

b. The minimum space required = 1.2 x 13.52" = 16.23" which is larger than the space available. Repeat steps 5 and 6 using the 9-tooth column in the selection tables.

c. For a 9-tooth sprocket R0635 would be selected. The minimum space would be 1.2 x 13.16" = 15.79" which meets the space restriction.

Determine Speed Ratio:

$$\text{Ratio} = \frac{\text{DriveR Shaft RPM}}{\text{DriveN Shaft RPM}} = \frac{90 \text{ RPM}}{44 \text{ RPM}} = 2.05 \text{ to } 1$$

Step 8. Drive Sprocket and Center Distance and Change Length

The nearest ratio to 2.05 to 1 is 2.00, with an 18-tooth DriveN sprocket. The minimum center distance is 2.06 feet and 9.38 feet of chain is required.

Determine the minimum center distance per the formula on page 140:

$$\text{Min. CDp} = (18 + 9) / 6 + 1 = 5.5 \text{ pitches} \quad \frac{18 + 9 + 1}{6} = 5.5$$

$$\text{Min. CD} = \frac{5.5 \times 4.5}{12} = 2.06 \text{ feet}$$

Determine the approximate chain length per the formula on page 141:

$$\begin{aligned} \text{LP} &= 2(5.5) + (18 + 9) / 2 + \\ &= (0.0258 \times (18 - 9)^2) / 5.5 = 24.9 \text{ pitches} \\ 25 \text{ pitches is the minimum (rounded up)} \\ L &= \frac{25 \times 4.5}{12} = 9.38 \text{ feet} \end{aligned}$$

Step 9. Drive and Drive Sprocket Material and Hub Selection

For the selection table used in Step 7, the required hub letter is N. Per the table on page 79 an N style hub is rated for 70,000 inch pounds and has a diameter of 6" and a length of 3". The plate thickness is 1.75". The total length through bore is 4.75" (3" + 1.75"). Since the sprocket is to be mounted on a reducer, it is recommended that the hub style is offset hubs, one side flush. This would need to be specified as such on the order.

The drive hub will need to handle 140,000 inch pounds since the speed ratio is 2 to 1. Per the table on page 79 a size P hub is required. This hub would be 8.75" in diameter and the length through bore would be 10.50".

Step 10. Lubrication

The type of lubrication for this drive selection, as shown in Selection Table 2, is oil bath.

DESIGN AND SELECTION

Service Factors

Use the table to find the application or the closest similar application. Note whether the operating time will be up to 10 hours a day or from 10 hours to 24 hours a day. In the column to the right of the application, select the Service Factor. This Service Factor determines the Design Horsepower for use in the Chain Selection Table.

Occasional and Intermittent Service or Engine Driven Applications

The Service Factors listed in Table 1 are for electric motor drives and normal conditions. For multi-cylinder engine driven applications and all applications operating intermittently up to 3 hours per day, use the values shown in the Converted Service Factors table. First, find the Service Factor of the same application operating 10 hours per day in Table 1. Next, in the first column of the chart below, find this same service factor in bold face type. Then, to the right under the desired hours service and prime mover locate the Converted Service Factor. For example, in the segment of Table 1 showing service factors by application on page 109, the Service Factor for a uniformly loaded belt conveyor at 10 hours a day is 1.00. From the chart, for the same application, the following are the service factors for various conditions:

1. Engine driven 10 hours per day; use 1.25 Service Factor.
2. Engine driven 3 hours intermittently; use 1.00 Service Factor.
3. Motor driven 3 hours intermittently; use .80 Service Factor.

Converted Service Factors					
10 Hrs. Per Day		24 Hrs. Per Day		Intermittent 3 Hrs Per Day ^①	
Motor	Engine	Motor	Engine	Motor	Engine
1.00	1.25	1.25	1.50	.80	1.00
1.25	1.50	1.50	1.75	1.00	1.25
1.75	2.00	2.00	2.25	1.50	1.75

^① For applications operating less than 3 hours per day and applications driven by single cylinder engines, refer to Factory for other service factors.
^② These service factors are based on the assumption that the system is free from serious critical and torsional vibrations and that maximum momentary or starting loads do not exceed 200% of the normal load.
 Note: For extremely wet or abrasive environments add 0.25 to the applicable service factor.

TABLE 1
SERVICE FACTORS LISTED BY INDUSTRY
 AGMA Recommendations... Factors are minimum and normal conditions are assumed.

Application	Service Factor		Application	Service Factor		Application	Service Factor		Application	Service Factor	
	10 Hours	24 Hours		10 Hours	24 Hours		10 Hours	24 Hours		10 Hours	24 Hours
Brewing & Distilling			Lumber Industry			Paper Mills			Rubber Industry		
Bottling Machinery	1.00	1.25	Barkers-Hydraulic Mechanical	1.25	1.50	Agitators (Mixers)	1.25	1.50	Calender	1.25	1.50
Brew Kettles Continuous	1.00	1.25	Burner Conveyor	1.25	1.50	Barket Auxiliaries, Hydraulic	1.25	1.50	Mixer	-	2.00
Can Filling Machinery	1.00	1.25	Chain & Drag Saw	1.50	1.75	Barker Mechanical	1.25	1.50	Mill (2 or more)	-	1.50
Cookers Continuous	1.00	1.25	Chain & Craneway Transfer	1.50	1.75	Barking Drum	1.75	2.00	Sheeter	-	1.50
Mash Tub Continuous	1.00	1.25	Debarking Drum	1.75	2.00	Beater & Pulper	1.25	1.50	Tire Building Machine	⊙	⊙
Scale Hopper Frequent Start	1.25	1.50	Edger & Gang Feed	1.25	1.50	Bleacher	1.00	1.25	Tire & Tube Press Opener	⊙	⊙
Clay Working Industry			Green Chain	1.50	1.75	Calendars	1.25	1.50	Tubers & Strainers	-	1.50
Brick Press	1.75	2.00	Line Rolls, Log Deck, Log Haul (Incline & Well Type)	1.75	2.00	Calendars, Super	1.75	2.00	Sewage Disposal		
Briquette Machine	1.75	2.00	Log Turning Device	1.75	2.00	Converting Machine (Except Cutters, Platters)	1.25	1.50	Bar Screws	1.00	1.25
Clay Working Machinery	1.25	1.50	Main Log Conveyor	1.75	2.00	Conveyor	1.00	1.25	Chemical Feeders	1.00	1.25
Pug Mill	1.25	1.50	Off Bearing Rolls	1.75	2.00	Couch	1.25	1.50	Collectors	1.00	1.25
Distilling (See Brewing)			Planer Feed & Floor Chains	1.25	2.50	Cutters, Platters	1.75	2.00	Dewatering Screens	1.25	1.50
Dredges			Planer Tilting Hoist	1.50	1.50	Cylinder	1.25	1.50	Grit Collectors	1.00	1.25
Cable Reels	1.25	1.50	Re-Saw Merry-Go-Round Conv	1.25	1.50	Dryer	1.25	1.50	Scum Breakers	1.25	1.50
Conveyors	1.25	1.50	Roll Cases, Slab Conveyor	1.75	2.00	Felt Stretcher	1.25	1.50	Slow or Rapid Mixer	1.25	1.50
Cutter Head Drives	1.75	2.00	Small Waste Conveyor - Belt	1.00	1.25	Felt Whipper	1.75	2.00	Sludge Collectors	1.00	1.25
Jig Drives	1.75	2.00	Small Waste Conveyor - Chain	1.25	1.50	Jordan	1.75	2.00	Thickeners	1.25	1.50
Maneuvering Winches	1.25	1.50	Sorting Table	1.25	1.50	Log Haul	1.75	2.00	Vacuum Filters	1.25	1.50
Pumps	1.25	1.50	Tipple Hoist Conv. & Drive	1.25	1.50	Press	1.00	1.25	Textile Industry		
Screen Drive	1.75	2.00	Transfer Conveyor & Rolls	1.25	1.50	Pulp Machine	1.25	1.50	Batcher, Calendar	1.25	1.50
Stackers	1.25	1.50	Tray Drive, Trimmer Feed & Waste Conveyor	1.25	1.50	Reel	1.25	1.50	Card Machine	1.25	1.50
Utility Winches	1.25	1.50	Oil Industry			Stock Chest	1.25	1.50	Cloth Finishing Machine	1.25	1.50
Food Industry			Chiller	1.25	1.50	Suction Roll	1.00	1.25	Dry Cans, Dryers	1.25	1.50
Beet Slicer	1.25	1.50	Oil Well Pumping	⊙	⊙	Washer & Thickeners	1.25	1.50	Dyeing Machinery	1.25	1.50
Bottling Machine, Can Filling	1.25	1.25	Paraffin Filter Pass	1.25	1.50	Winders	1.00	1.25	Knitting Machine	⊙	⊙
Cooker	1.00	1.25	Rotary Kiln	1.25	1.50				Loom, Mangle, Napper Pads	1.25	1.50
Dough Mixer, Meat Grinder	1.25	1.50							Range Drives	⊙	⊙
									Slashers, Soapers	1.25	1.50
									Spinners	1.25	1.50
									Tenter Frames, Washers	1.25	1.50
									Winders (Except Batchers)	1.25	1.50

[⊙] Refer to Factory.
 Table 1 extracted from AGMA Standard Application Classification for Gearmotors (AGMA 150.02) with the permission of the American Gear Manufacturers Association, One Thomas Circle, Washington 5, D.C.

DESIGN AND SELECTION

TABLE 1

SERVICE FACTORS LISTED BY INDUSTRY

AGMA Recommendations... Factors are minimum and normal conditions are assumed.



Application	Service Factor		Application	Service Factor		Application	Service Factor		Application	Service Factor	
	10 Hours	24 Hours		10 Hours	24 Hours		10 Hours	24 Hours		10 Hours	24 Hours
Agitators	1.25	1.50	or Fed: Apron, Assembly, Belt			Generator (Not Welding)	1.00	1.25	Proportioning	1.25	1.50
Paper Mills (Mixers)	1.25	1.50	Bucket, Chain, Flight, Oven or			Welding	①	①	Single Acting, 3 or more Cyl.	1.25	1.50
Pure Liquid (Blade or Prop.)	1.00	1.25	Screw	1.00	1.25	Gravity Discharge Elevator	1.00	1.25	Double Acting, 2 or more Cyl.	1.25	1.50
Liquids & Solids	1.25	1.50	Conveyors - Heavy Duty, Not			Grit Collector (Sewage)	1.00	1.25	Rotary Gear, Lobe or Vane	1.00	1.25
Variable Density Liquids	1.25	1.50	Uniformly Fed: Apron			Hammer Mills	1.75	2.00	Punch Press - Gear Driven	1.75	2.00
Apron Conveyor			Assembly, Belt, Bucket, Chain,			Induced Draft Fan	1.25	1.50	Reciprocating Compressor		
Uniform	1.00	1.25	Flight, Oven or Screw	1.25	1.50	Jordans (Paper)	1.75	2.00	Single Cylinder	1.25	1.50
Heavy Duty	1.25	1.50	Conveyors - Severe Duty:			Kilns (Rotary)	1.25	1.50	Multi-Cylinder	1.75	2.00
Apron Feeder	1.25	1.50	Reciprocating, Shaker	1.75	2.00	Laundry Washers & Tumblers	1.25	1.50	Reciprocating		
Assembly Conveyor			Conveyors Live Rolls	①	①	Line Shafts			Conveyor, Feeder	1.75	2.00
Uniform	1.00	1.25	Cookers (Brewing and Distilling)			Heavy Shock Load	1.75	2.00	Pump, 3 or more Cyl.	1.25	1.50
Heavy Duty	1.25	1.50	Food	1.00	1.25	Moderate Shock Load	1.25	1.50	Reel (Paper)	1.25	1.50
Ball Mills	-	1.50	Cooling Tower Fans			Uniform Load	1.00	1.25	Rod Mills	-	1.50
Barge Haul Puller	1.75	2.00	Forced Draft	①	①	Live Roll Conveyors	①	①	Rotary Pumps	1.00	1.25
Barking Drum	1.75	2.00	Induced Draft	1.25	1.50	Lobe Blowers or Compressors	1.25	1.50	Rotary Screen	1.25	1.50
Hydraulic Auxiliaries	1.2	1.50	Couch (Paper)	1.25	1.50	Log Haul (Paper)	1.75	2.00	Rubber Industry	②	②
Mechanical	1.25	1.50	Cranes & Hoists			Looms (Textile)	1.25	1.50	Scale Hopper (Brewing)	1.25	1.50
Bar Screen (Sewage)	1.00	1.25	Heavy Duty	1.75	2.00	Lumber Industry	②	②	Screens		
Batchers (Textile)	1.25	1.50	Cranes & Hoists - Medium			Machine Tools			Air Washing	1.00	1.25
Beater & Pulper (Paper)	1.25	1.50	Duty: Reversing, Skip, Travel			Auxiliary Drives	1.00	1.25	Dewatering	1.25	1.50
Belt Conveyor			or Trolley Motion	1.25	1.50	Bending Roll	1.25	1.50	Rotary Stone or Gravel	1.25	1.50
Uniform	1.00	1.25	Crushers - Ore or Stone	1.75	2.00	Main Drives	1.25	1.50	Traveling Water Intake	1.00	1.25
Heavy Duty	1.25	1.50	Cutters (Paper)	1.75	2.00	Notching Press (Belted)	①	①	Screw Conveyor		
Belt Feeder	1.25	1.50	Cylinder (Paper)	1.25	1.50	Plate Planer	1.75	2.00	Uniform	1.00	1.25
Bending Roll (Mach.)	1.25	1.50	Dewatering Screen			Punch Press (Gear)	1.75	2.00	Heavy Duty or Feeder	1.25	1.50
Bleacher (Paper)	1.00	1.25	(Sewage)	1.25	1.50	Tapping Machines	1.75	2.00	Scum Breaker (Sewage)	1.25	1.50
Blowers			Disc Feeder	1.00	1.25	Mangle (Textile)	1.25	1.50	Service Elevator Hand Lift	1.75	-
Centrifugal	1.00	1.25	Distilling	②	②	Man Lifts (Elevator)	①	①	Sewage Disposal	②	②
Lobe	1.25	1.50	Double Action Pump			Mash Tubs (Brewing)	1.00	1.25	Shaker Conveyor	1.75	2.00
Vane	1.00	1.25	2 or more Cylinders	1.25	1.50	Meat Grinder (Food)	1.25	1.50	Sheeter (Rubber)	-	1.50
Bottling Machinery	1.00	1.25	Single Cylinder	①	①	Metal Mills			Single Action Pump		
Brewing	②	②	Dough Mixer (Food)	1.25	1.50	Draw Bench Carriage	1.25	1.50	1 or 2 Cylinder	①	①
Brick Press (Clay Working)	1.75	2.00	Draw Bench			Draw Bench Main Drive	1.25	1.50	3 or More	1.25	1.50
Briquette Machine			Carriage	1.25	1.50	Forming Machine	1.75	2.00	Single Cylinder Pump	①	①
(Clay Working)	1.75	2.00	Main Drive	1.25	1.50	Slitters	1.25	1.50	Skip Hoist	1.25	1.50
Bucket			Dredges	②	②	Table Conveyors Non-Rev.	1.25	1.50	Slab Pusher	7.25	7.50
Conveyor Uniform	1.00	1.25	Dyeing Machine (Textile)	1.25	1.50	Wire Drawing of Flattening	1.25	1.50	Slitters	1.25	1.50
Conveyor Heavy Duty	1.25	1.50	Dryers (Paper)	1.25	1.50	Wire Winding	1.25	1.50	Sludge Collector		
Elevator Continuous	1.00	1.25	Dryers & coolers			Mills Rotary			(Sewage)	1.00	1.25
Elevator Uniform Load	1.00	1.25	(Mills Rotary)	-	1.50	Ball	1.75	2.00	Soapers (Textile)	1.25	1.50
Elevator Heavy Duty	1.25	1.50	Elevators			Cement Kilns	①	①	Spinners (Textile)	1.25	1.50
Calenders			Bucket Uniform Load	1.00	1.25	Coolers, Dryers, Kilns	1.25	1.50	Steering Gear	1.25	1.50
(Paper)	1.25	1.50	Bucket Heavy Load	1.25	1.50	Pebble, Rod, Tumbling Barrels	1.75	2.00	Stock Chest (Paper)	1.25	1.50
Super (Paper)	1.75	2.00	Bucket Continuous	1.00	1.25	Mine Fan	1.25	1.50	Stokers	1.00	1.25
(Rubber) (Textile)	1.25	1.50	Centrifugal Discharge	1.00	1.25	Mixers			Stone Crushers	1.75	2.00
Cane Knives	-	1.50	Escalators	1.00	1.25	Concrete (Cont)	1.25	1.50	Suction Roll (Paper)	1.00	1.25
Can Filling Machines	1.00	1.25	Freight	1.25	1.50	Concrete (Inter)	1.25	1.50	Table Conveyor		
Card Machine (Textile)	1.25	1.50	Gravity Discharge	1.00	1.25	Constant Density	1.00	1.25	Non-Reversing	1.25	1.50
Car Dumpers	1.75	2.00	Man Lift, Passenger	①	①	Variable Density	1.25	1.50	Tapping Machines	-	2.00
Car Pullers	1.25	1.50	Service Hand Lift	1.75	-	Rubber	-	2.00	Tenter Frames		
Cement Kilns	①	①	Escalators	1.00	1.25	Sewage	1.25	1.50	(Textile)	1.25	1.50
Centrifugal			Fans			Nappers (Textile)	1.25	1.50	Textile Industry	②	②
Blowers, Compressors,			Centrifugal	1.00	1.25	Notching Press			Thickeners (Sewage)	1.25	1.50
Discharge Elevators, Fans			Cooling Tower Induced Dr.	1.25	1.50	Belt Driven	1.00	1.25	Tire Building Machine	①	①
or Pumps	1.00	1.25	Cooling Tower - Forced Dr.	①	①	Oil Industry	②	②	Tire & Tube Press Opener	①	①
Chain Conveyor			Induced Draft	1.25	1.50	Ore Crusher	1.75	2.00	Travel Motion (Crane)	1.25	1.50
Uniform	1.00	1.25	Large Industrial	1.25	1.50	Oven Conveyor - Uniform	1.00	1.25	Trolley Motion (Crane)	1.25	1.50
Heavy Duty	1.25	1.50	Large (Mine, etc.)	1.25	1.50	Heavy	1.25	1.50	Tumbling Barrels	1.75	2.00
Chemical Feeder (Sewage)	1.00	1.25	Light (Small Diameter)	1.00	1.25	Paper Mill	②	②	Vacuum Filters		
Classifiers	1.00	1.25	Feeders			Passenger Elevator	①	①	(Sewage)	1.25	1.50
Classifiers	1.25	1.50	Apron or Belt	1.25	1.50	Pebble Mills	-	1.50	Vane Blower	1.00	1.25
Clay Working	①	②	Disc	1.00	1.25	Planer (Reversing)	1.75	2.00	Washers and Thickeners		
Collectors (Sewage)	1.00	1.25	Reciprocating	1.75	2.00	Presses (Paper)	1.00	1.25	(Paper)	1.25	1.50
Compressors			Screw	1.25	1.50	(Printing)	1.00	1.25	Winches, Maneuvering		
Centrifugal	1.00	1.25	Felt			Propeller Type Agitator			(Dredge)	1.25	1.50
Lobe, Recipr. Multi-Cylinder	1.25	1.50	Stretcher (Paper)	1.25	1.50	(Pure Liquid)	1.00	1.25	Winders		
Recipr. Single-Cylinder	1.75	2.00	Whipper (Paper)	1.75	2.00	Proportioning Pump	1.25	1.50	(Paper)	1.00	1.25
Concrete Mixers			Flight			Pug Mills (Clay)	1.25	1.50	(Textile)	1.25	1.50
Continuous	1.25	1.50	Conveyor Uniform	1.00	1.25	Pullers (Barge Haul)	1.75	2.00	Windlass	1.25	1.50
Intermittent	1.25	1.50	Conveyor Heavy	1.25	1.50	Pulp Machines (Paper)	1.25	1.50	Wire		
Converting Machine			Food Industry	②	②	Pulverizers (Hammermill)	1.75	2.00	Drawing Machine	1.25	1.50
(Paper)	1.25	1.50	Forming Machine			Pumps			Winding Machine	1.25	1.50
Conveyors - Uniformly Loaded			(Metal Mills)	1.75	2.00	Centrifugal	1.00	1.25			
			Freight Elevator	1.25	1.50						

① Refer to Factory.
② Page 108.

DESIGN AND SELECTION

TABLE 2
DRIVE CHAIN SELECTION TABLES

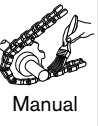
Note: Rex® drive chain selections are displayed in the tables. To interchange Link-Belt® and Rex chain numbers see pages 34-35.

Table 2											
RPM Driver Sprocket	DESIGN HORSEPOWER (DHP) = HP x SF For (SF) see pages 108-109				Type of Lubrication	RPM Driver Sprocket	DESIGN HORSEPOWER (DHP) = HP x SF For (SF) see pages 108-109				Type of Lubrication
	DRIVER SPROCKET – NO. OF TEETH LARGEST KEYSEATED BORE						DRIVER SPROCKET – NO. OF TEETH LARGEST KEYSEATED BORE				
	9T	12T	15T	Hub Letter ^②			9T	12T	15T	Hub Letter ^②	
1 DHP											
17 1/2–20	R432 1 15/16 3140 1 11/16	R362 2 11/16	R362 3 11/16	E	 Manual	4–5	R514 2 15/16 3180 ①	R3112 7/16 3180 3 11/16	R588 5 15/16 3140 3 15/16	H	 Manual
15–17 1/2	R432 1 15/16 3140 1 11/16	R362 2 11/16	R362 3 11/16	E		3–4	1030 3 7/16 3180 ①	R3112 3 7/16 3180 3 11/16	R3112 4 15/16 3140 3 15/16	I	
12 1/2–15	R778 3 11/16 3140 1 11/16	R432 2 11/16 3120 2 3/16	R362 3 11/16	E		2–3	1030 4 7/16	1030 5 15/16 3180 3 11/16	R514 5 15/16 3160 4 7/16	K	
10–12 1/2	R778 3 7/16 3160 1 15/16	R778 4 15/16 3120 2 3/16	R432 3 11/16	F		1–2	R1248 5 7/16	R1037 5 7/16	R1033 8 3180 4 15/16	N	
7 1/2–10	R588 3 7/16 3160 1 15/16	R778 4 15/16 3140 2 11/16	R778 4 15/16 3120 3 3/16	F		3/4–1	R1248 5 7/16	R1037 4 15/16	R1037 8 3180 4 15/16	O	
5–7 1/2	R558 3 3/16 3180 2 3/16	R588 4 15/16 3160 3 3/16	R778 5 7/16 3120 3 3/16	G		1/2–3/4	R1248 5 7/16	AX1568 5 7/16	R1037 8	P	
						1/4–1/2	RO1306 9	RX238 7	RX238 10	S	
2 DHP											
35–40	R432 1 15/16 3140 1 11/16	R362 2 11/16	R362 3 11/16	E	 Manual	7 1/2–10	R514 2 15/16 3180 ①	R3112 3 7/16 3140 2 11/16	R3112 4 15/16 3140 3 15/16	H	 Manual
30–35	R432 1 15/16 3140 1 11/16	R362 2 11/16	R362 3 11/16	E		5–7 1/2	1030 3 7/16	R514 4 7/16 3160 3 9/16	R3112 4 15/16 3140 3 15/16	J	
25–30	R778 3 11/16 3140 1 11/16	R432 2 11/16	R362 3 11/16	E		4–5	R1037 3 15/16	1030 5 15/16 3180 3 11/16	R514 5 15/16 3160 4 7/16	K	
20–25	R778 3 7/16 3160 1 15/16	R778 4 15/16 3120 2 3/16	R432 3 11/16	F		3–4	R1037 3 15/16	R1037 4 15/16 3180 3 11/16	R1033 8 3180 4 15/16	L	
17 1/2–20	R588 3 7/16 3160 1 15/16	R778 4 15/16 3140 2 3/16	R432 3 11/16	F		2–3	R1248 5 7/16	R1037 5 15/16	R1037 8 3180 4 15/16	N	
15–17 1/2	R588 3 7/16 3160 1 15/16	R778 4 15/16 3140 2 11/16	R778 4 15/16 3120 3 3/16	F		1–2	R1248 5 7/16	RX238 7	AX1568 8 1/2	P	
12 1/2–15	R514 2 7/16 3180 2 3/16	R588 4 15/16 3120 2 3/16	R778 5 7/16 3120 3 3/16	G		3/4–1	RO635 5 7/16	R1248 7 1/2	RX238 10	Q	
10–12 1/2	R514 2 7/16 3180 2 3/16	R3112 3 7/16 3140 2 11/16	R588 5 7/16 3120 3 3/16	G		1/2–3/4	RO1306 9	R1248 9	RX238 10	S	
					1/4–1/2	X1307 10	RX1207 ①	RO635 ①	U		
3 DHP											
45–50	R432 1 15/16 3140 1 11/16	R362 2 11/16	R362 3 11/16	E	 Manual	10–12 1/2	1030 3 7/16 3180 ①	R514 4 7/16 3160 3 3/16	R3112 4 15/16 3140 3 15/16	I	 Manual
40–45	R778 3 11/16 3140 1 11/16	R432 2 11/16	R362 3 11/16	E		7 1/2–10	R1033 3 7/16	1030 5 15/16 3160 3 3/16	R514 5 15/16 3140 3 15/16	J	
35–40	R778 3 11/16 3140 1 11/16	R432 2 11/16	R362 3 11/16	E		5–7 1/2	R1037 3 15/16	R1033 5 15/16 3180 3 11/16	1030 7 1/2 3160 4 7/16	K	
30–35	R778 3 7/16 3160 1 15/16	R778 4 15/16 3120 2 3/16	R432 3 11/16	F		4–5	R1037 3 15/16	R1037 5 7/16 3180 3 11/16	R1037 8 3160 4 7/16	L	
25–30	R588 3 7/16 3160 1 15/16	R778 4 15/16 3140 2 3/16	R432 3 11/16	F		3–4	R1248 5 7/16	AX1568 5 7/16	R1037 8 3180 4 15/16	N	
20–25	R514 2 7/16 3180 2 3/16	R588 4 15/16 3120 2 3/16	R778 5 7/16 3120 3 3/16	G		2–3	R1248 5 7/16	RX238 7	AX1568 8 1/2	O	
17 1/2–20	R514 2 7/16 3180 2 3/16	R588 4 15/16 3120 2 3/16	R778 5 7/16 3120 3 3/16	G		1–2	RX1207 6 1/2	R1248 7 1/2	RX238 10	Q	
15–17 1/2	R514 2 7/16 3180 2 3/16	R3112 3 7/16 3140 2 11/16	R588 5 7/16 3120 3 3/16	G		3/4–1	RO1306 9	RX1245 9	R1248 10	S	
						1/2–3/4	X1307 10	RO635 9 1/2	RO635 ①	T	
12 1/2–15	R514 2 15/16 3180 ①	R3112 3 7/16 3140 2 11/16	R3112 4 15/16 3140 3 15/16	H	1/4–1/2	①	RX1207 ①	RX1207 ①	X		

Note: 1. 3100 Series chain operates over roller chain cut tooth sprockets.

2. Fabricated steel sprockets are recommended.





① Consult Rexnord

② Hub size letter – See page 79.

DESIGN AND SELECTION

TABLE 2 (Cont'd.)
DRIVE CHAIN SELECTION TABLES

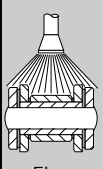
Note: Rex® drive chain selections are displayed in the tables. To interchange Link-Belt® and Rex chain numbers see pages 34-35.

Table 2 – (Cont'd.)												
RPM Driver Sprocket	DESIGN HORSEPOWER (DHP) = HP x SF For (SF) see pages 108-109				Type of Lubrication	RPM Driver Sprocket	DESIGN HORSEPOWER (DHP) = HP x SF For (SF) see pages 108-109				Type of Lubrication	
	DRIVER SPROCKET – NO. OF TEETH LARGEST KEYSEATED BORE						DRIVER SPROCKET – NO. OF TEETH LARGEST KEYSEATED BORE					
	9T	12T	15T	Hub Letter [Ⓢ]			9T	12T	15T	Hub Letter [Ⓢ]		
4 DHP												
80 – 90	R362 1 ¹⁵ / ₁₆ 3120 1 ⁷ / ₁₆	R362 2 ¹⁵ / ₁₆	R362 3 ¹¹ / ₁₆	D	 Manual	15 – 17 ¹ / ₂	1030 3 ¹¹ / ₁₆ 3180 [Ⓢ]	R514 4 ⁷ / ₁₆ 3160 3 ³ / ₁₆	R3112 4 ¹⁵ / ₁₆ 3140 3 ¹⁵ / ₁₆	H	 Manual	
70 – 80	R432 1 ¹⁵ / ₁₆ 3140 1 ¹¹ / ₁₆	R362 2 ¹¹ / ₁₆	R362 3 ¹¹ / ₁₆	E		12 ¹ / ₂ – 15	R1035 3 ⁷ / ₁₆	1030 5 ¹⁵ / ₁₆ 3160 3 ³ / ₁₆	R514 5 ¹⁵ / ₁₆ 3140 3 ¹⁵ / ₁₆	I		
60 – 70	R432 1 ¹⁵ / ₁₆ 3140 1 ¹¹ / ₁₆	R362 2 ¹¹ / ₁₆	R362 3 ¹¹ / ₁₆	E		10 – 12 ¹ / ₂	R1037 3 ¹⁵ / ₁₆	R1033 5 ¹⁵ / ₁₆ 3160 3 ³ / ₁₆	1030 7 3160 4 ⁷ / ₁₆	J		
50 – 60	R778 3 ¹¹ / ₁₆ 3140 1 ¹¹ / ₁₆	R432 2 ¹¹ / ₁₆	R362 3 ¹¹ / ₁₆	E		7 ¹ / ₂ – 10	R1037 3 ¹⁵ / ₁₆	R1037 5 ⁷ / ₁₆ 3180 3 ¹¹ / ₁₆	R1033 7 ¹ / ₂ 3160 4 ⁷ / ₁₆	K		
45 – 50	R778 3 ¹¹ / ₁₆ 3140 1 ¹¹ / ₁₆	R432 2 ¹¹ / ₁₆ 3120 2 ³ / ₁₆	R362 3 ¹¹ / ₁₆	E		5 – 7 ¹ / ₂	R1037 3 ¹⁵ / ₁₆	R1037 5 ⁷ / ₁₆ 3180 3 ¹¹ / ₁₆	R1037 8 3160 4 ⁷ / ₁₆	M		
40 – 45	R778 3 ⁷ / ₁₆ 3160 1 ¹⁵ / ₁₆	R778 4 ¹⁵ / ₁₆ 3120 2 ³ / ₁₆	R432 3 ¹¹ / ₁₆	F		4 – 5	R1248 5 ⁷ / ₁₆	AX1568 5 ⁷ / ₁₆	R1037 8 3180 4 ¹⁵ / ₁₆	N		
35 – 40	R778 3 ⁷ / ₁₆ 3160 1 ¹⁵ / ₁₆	R778 4 ¹⁵ / ₁₆ 3120 2 ³ / ₁₆	R432 3 ¹¹ / ₁₆ 3120 3 ³ / ₁₆	F		3 – 4	R1248 5 ⁷ / ₁₆	RX238 7	AX1568 8 ¹ / ₂ 3180 4 ¹⁵ / ₁₆	O		
30 – 35	R588 3 ⁷ / ₁₆ 3160 1 ¹⁵ / ₁₆	R778 4 ¹⁵ / ₁₆ 3120 2 ³ / ₁₆	R778 4 ¹⁵ / ₁₆ 3120 3 ³ / ₁₆	F		2 – 3	R1248 5 ⁷ / ₁₆	RX238 7	RX238 10	P		
25 – 30	R514 2 ⁷ / ₁₆ 3180 2 ³ / ₁₆	R588 4 ¹⁵ / ₁₆ 3140 2 ¹¹ / ₁₆	R778 5 ⁷ / ₁₆ 3120 3 ³ / ₁₆	G		1 – 2	RO1306 9	RX1245 9	R1248 10	S		
20 – 25	R514 2 ⁷ / ₁₆ 3180 2 ³ / ₁₆	R3112 3 ⁷ / ₁₆ 3140 2 ¹¹ / ₁₆	R588 5 ⁷ / ₁₆ 3120 3 ³ / ₁₆	G		3/4 – 1	RO1306 9	RX1207 [Ⓢ]	RO635 [Ⓢ]	T		
17 ¹ / ₂ – 20	R514 2 ¹⁵ / ₁₆ 3180 [Ⓢ]	R3112 3 ⁷ / ₁₆ 3140 2 ¹¹ / ₁₆	R588 5 ¹⁵ / ₁₆ 3140 3 ¹⁵ / ₁₆	H		1/2 – 3/4	X1307 10	RX1207 [Ⓢ]	RO635 [Ⓢ]	U		
						1/4 – 1/2		RO1306 [Ⓢ]	RX1207 [Ⓢ]	G		
5 DHP												
100 – 125	R362 1 ¹⁵ / ₁₆ 3120 1 ⁷ / ₁₆	R362 2 ¹⁵ / ₁₆	R362 3 ¹¹ / ₁₆	D	 Flow	17 ¹ / ₂ – 20	1030 3 ⁷ / ₁₆ 3180 [Ⓢ]	R514 4 ⁷ / ₁₆ 3160 3 ³ / ₁₆	R3112 4 ¹⁵ / ₁₆ 3140 3 ¹⁵ / ₁₆	I	 Manual	
90 – 100	R432 1 ¹⁵ / ₁₆ 3120 1 ⁷ / ₁₆	R362 2 ¹⁵ / ₁₆	R362 3 ¹¹ / ₁₆	D		15 – 17 ¹ / ₂	R1037 3 ³ / ₁₆	1030 5 ¹⁵ / ₁₆ 3160 3 ³ / ₁₆	R514 5 ¹⁵ / ₁₆ 3160 4 ⁷ / ₁₆	I		
80 – 90	R432 1 ¹⁵ / ₁₆ 3120 1 ¹¹ / ₁₆	R362 2 ¹¹ / ₁₆	R362 3 ¹¹ / ₁₆	E		12 ¹ / ₂ – 15	R1037 3 ¹⁵ / ₁₆	R1033 5 ¹⁵ / ₁₆ 3160 3 ³ / ₁₆	1030 7 3160 4 ⁷ / ₁₆	J		
70 – 80	R432 1 ¹⁵ / ₁₆ 3140 1 ¹¹ / ₁₆	R362 2 ¹¹ / ₁₆	R362 3 ¹¹ / ₁₆	E		10 – 12 ¹ / ₂	R1037 3 ¹⁵ / ₁₆	R1035 5 ⁷ / ₁₆ 3180 3 ¹¹ / ₁₆	R1033 7 ¹ / ₂ 3160 4 ⁷ / ₁₆	K		
60 – 70	R778 3 ¹¹ / ₁₆ 3140 1 ¹¹ / ₁₆	R432 2 ¹¹ / ₁₆	R362 3 ¹¹ / ₁₆	E		7 ¹ / ₂ – 10	AX1568 3 ¹¹ / ₁₆	R1037 5 ⁷ / ₁₆ 3180 3 ¹¹ / ₁₆	R1037 8 3180 4 ¹⁵ / ₁₆	L		
50 – 60	R778 3 ⁷ / ₁₆ 3160 1 ¹⁵ / ₁₆	R788 4 ¹⁵ / ₁₆ 3120 2 ³ / ₁₆	R432 3 ¹¹ / ₁₆	F	5 – 7 ¹ / ₂	R1248 5 ⁷ / ₁₆	AX1568 5 ⁷ / ₁₆	R1037 8 3180 4 ¹⁵ / ₁₆	N			
45 – 50	R588 3 ⁷ / ₁₆ 3160 1 ¹⁵ / ₁₆	R788 4 ¹⁵ / ₁₆ 3120 2 ³ / ₁₆	R432 3 ¹¹ / ₁₆	F	4 – 5	R1248 5 ⁷ / ₁₆	RX238 7	AX1568 8 ¹ / ₂	O			
40 – 45	R588 3 ⁷ / ₁₆ 3160 1 ¹⁵ / ₁₆	R778 4 ¹⁵ / ₁₆ 3120 2 ³ / ₁₆	R778 4 ¹⁵ / ₁₆ 3120 3 ³ / ₁₆	F	3 – 4	R1248 5 ⁷ / ₁₆	RX238 7	RX238 10	P			
35 – 40	R514 2 ⁷ / ₁₆ 3180 2 ³ / ₁₆	R588 4 ¹⁵ / ₁₆ 3140 2 ¹¹ / ₁₆	R778 5 ⁷ / ₁₆ 3120 3 ³ / ₁₆	G	2 – 3	RO635 5 ⁷ / ₁₆	R1248 7 ¹ / ₂	RX238 10	Q			
30 – 35	R514 2 ⁷ / ₁₆ 3180 2 ³ / ₁₆	R588 4 ¹⁵ / ₁₆ 3140 2 ¹¹ / ₁₆	R778 5 ⁷ / ₁₆ 3120 3 ³ / ₁₆	G	1 – 2	RO1306 9	RO635 9 ¹ / ₂	RX1245 10	S			
25 – 30	R514 2 ⁷ / ₁₆ 3180 2 ³ / ₁₆	R3112 3 ⁷ / ₁₆ 3140 2 ¹¹ / ₁₆	R588 5 ⁷ / ₁₆ 3140 3 ¹⁵ / ₁₆	G	3/4 – 1	X1307 10	RX1207 [Ⓢ]	RO635 [Ⓢ]	U			
20 – 25	R514 2 ¹⁵ / ₁₆ 3180 [Ⓢ]	R3112 3 ⁷ / ₁₆ 3160 3 ³ / ₁₆	R3112 4 ¹⁵ / ₁₆ 3140 3 ¹⁵ / ₁₆	H	1/2 – 3/4	X1307 9 ¹ / ₂	RX1207 [Ⓢ]	RX1207 [Ⓢ]	W			
					1/4 – 1/2	[Ⓢ]	RO1306 [Ⓢ]	RO1306 [Ⓢ]	Z			

Note: 1. 3100 Series chain operates over roller chain cut tooth sprockets.
2. Fabricated steel sprockets are recommended.



[Ⓢ] Consult Rexnord

[Ⓢ] Hub size letter – See page 79.

DESIGN AND SELECTION

TABLE 2 (Cont'd.)
DRIVE CHAIN SELECTION TABLES

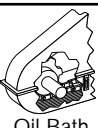
Note: Rex® drive chain selections are displayed in the tables. To interchange Link-Belt® and Rex chain numbers see pages 34-35.

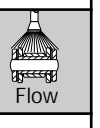
Table 2 – (Cont'd.)											
RPM Driver Sprocket	DESIGN HORSEPOWER (DHP) = HP x SF For (SF) see pages 108-109				Type of Lubrication	RPM Driver Sprocket	DESIGN HORSEPOWER (DHP) = HP x SF For (SF) see pages 108-109				Type of Lubrication
	DRIVER SPROCKET – NO. OF TEETH LARGEST KEYSEATED BORE						DRIVER SPROCKET – NO. OF TEETH LARGEST KEYSEATED BORE				
	9T	12T	15T	Hub Letter ²			9T	12T	15T	Hub Letter ²	
7 1/2 DHP											
300 – 350	R362 1 ¹¹ / ₁₆ 3120 1 ⁷ / ₁₆	R362 2 ¹⁵ / ₁₆	R362 3 ¹¹ / ₁₆	C	 Oil Bath	35 – 40	R514 2 ¹⁵ / ₁₆ 3180 ①	R3112 3 ⁷ / ₁₆ 3160 3 ³ / ₁₆	R588 5 ¹⁵ / ₁₆ 3140 3 ¹⁵ / ₁₆	H	 Manual
250 – 300	R362 1 ¹¹ / ₁₆ 3120 1 ⁷ / ₁₆	R362 2 ¹⁵ / ₁₆	R362 3 ¹¹ / ₁₆	C		30 – 35	R514 2 ¹⁵ / ₁₆ 3180 ①	R3112 3 ⁷ / ₁₆ 3160 3 ³ / ₁₆	R3112 4 ¹⁵ / ₁₆ 3160 4 ⁷ / ₁₆	H	
200 – 250	R362 1 ¹⁵ / ₁₆ 3120 1 ⁷ / ₁₆	R362 2 ¹⁵ / ₁₆	R362 3 ¹¹ / ₁₆	D		25 – 30	R1033 3 ¹¹ / ₁₆ 3180 ①	R514 4 ⁷ / ₁₆ 3160 3 ³ / ₁₆	R3112 4 ¹⁵ / ₁₆ 3160 4 ⁷ / ₁₆	I	
175 – 200	R432 1 ¹⁵ / ₁₆ 3120 1 ⁷ / ₁₆	R362 2 ¹⁵ / ₁₆	R362 3 ¹¹ / ₁₆	D		20 – 25	R1037 3 ³ / ₁₆	1030 5 ¹⁵ / ₁₆ 3160 3 ³ / ₁₆	R514 5 ¹⁵ / ₁₆ 3160 4 ⁷ / ₁₆	I	
150 – 175	R432 1 ¹⁵ / ₁₆ 3120 1 ⁷ / ₁₆	R362 2 ¹⁵ / ₁₆	R362 3 ¹¹ / ₁₆	D		17 1/2 – 20	R1037 3 ¹⁵ / ₁₆	R1033 5 ¹⁵ / ₁₆ 3180 3 ¹¹ / ₁₆	1030 7 3160 4 ⁷ / ₁₆	J	
125 – 150	R432 1 ¹⁵ / ₁₆ 3140 1 ¹¹ / ₁₆	R362 2 ¹¹ / ₁₆	R362 3 ¹¹ / ₁₆	E		15 – 17 1/2	R1037 3 ¹⁵ / ₁₆	R1035 5 ⁷ / ₁₆ 3180 3 ¹¹ / ₁₆	R1033 7 ¹ / ₂ 3160 4 ⁷ / ₁₆	K	
100 – 125	R778 3 ¹¹ / ₁₆ 3140 1 ¹¹ / ₁₆	R362 2 ¹¹ / ₁₆ 3120 2 ³ / ₁₆	R362 3 ¹¹ / ₁₆	E		12 1/2 – 15	AX1568 3 ¹¹ / ₁₆	R1037 5 ⁷ / ₁₆ 3180 3 ¹¹ / ₁₆	R1037 7 ¹ / ₂ 3180 4 ¹⁵ / ₁₆	K	
90 – 100	R778 3 ¹¹ / ₁₆ 3140 1 ¹¹ / ₁₆	R432 2 ¹¹ / ₁₆ 3120 2 ³ / ₁₆	R362 3 ¹¹ / ₁₆ 3120 3 ³ / ₁₆	E		10 – 12 1/2	RX238 4 ⁷ / ₁₆	AX1568 5 ⁷ / ₁₆ 3180 3 ¹¹ / ₁₆	R1037 8 3180 4 ¹⁵ / ₁₆	L	
80 – 90	R778 3 ⁷ / ₁₆ 3160 1 ¹⁵ / ₁₆	R432 2 ⁷ / ₁₆ 3120 2 ³ / ₁₆	R432 3 ¹¹ / ₁₆ 3120 3 ⁷ / ₁₆	F		7 1/2 – 10	RX238 4 ⁷ / ₁₆	RX238 7	AX1568 8 ¹ / ₂ 3180 4 ¹⁵ / ₁₆	N	
70 – 80	R588 3 ⁷ / ₁₆ 3160 1 ¹⁵ / ₁₆	R778 4 ¹⁵ / ₁₆ 3140 2 ¹¹ / ₁₆	R432 3 ¹¹ / ₁₆ 3120 3 ³ / ₁₆	F		5 – 7 1/2	R1248 5 ⁷ / ₁₆	RX238 7	RX238 10	O	
60 – 70	R588 3 ⁷ / ₁₆ 3160 1 ¹⁵ / ₁₆	R778 4 ¹⁵ / ₁₆ 3140 2 ¹¹ / ₁₆	R778 4 ¹⁵ / ₁₆ 3140 3 ¹⁵ / ₁₆	F		4 – 5	RX1245 5 ⁷ / ₁₆	RX1248 8	RX238 10	P	
50 – 60	R588 3 ³ / ₁₆ 3180 2 ³ / ₁₆	R588 4 ¹⁵ / ₁₆ 3140 2 ¹¹ / ₁₆	R778 5 ⁷ / ₁₆ 3140 3 ¹⁵ / ₁₆	G		3 – 4	RO635 5 ⁷ / ₁₆	RX1245 9	R1248 10	Q	
45 – 50	R514 2 ¹⁵ / ₁₆ 3180 2 ³ / ₁₆	R588 4 ¹⁵ / ₁₆ 3140 2 ¹¹ / ₁₆	R778 5 ⁷ / ₁₆ 3140 3 ¹⁵ / ₁₆	G		2 – 3	RO1306 9	RO635 9 ¹ / ₂	RX1245 10	R	
40 – 45	R514 2 ¹⁵ / ₁₆ 3180 2 ³ / ₁₆	R588 4 ¹⁵ / ₁₆ 3160 3 ³ / ₁₆	R588 5 ⁷ / ₁₆ 3140 3 ¹⁵ / ₁₆	G		1 – 2	X1307 10	RX1207 ①	RX1207 ①	U	
					3/4 – 1	X1307 9 ¹ / ₂	RO1306 ①	RX1207 ①	W		
					1/2 – 3/4	①	RO1306 ①	RO1306 ①	Y		
					1/4 – 1/2	①	①	X1307 ①	①		
10 DHP											
300 – 350	R423 1 ¹⁵ / ₁₆ 3120 1 ⁷ / ₁₆	R362 2 ¹⁵ / ₁₆	R362 3 ¹¹ / ₁₆	D	 Oil Bath	40 – 45	1030 3 ¹¹ / ₁₆ 3180 ①	R3112 3 ⁷ / ₁₆ 3160 3 ³ / ₁₆	R3112 4 ¹⁵ / ₁₆ 3160 4 ⁷ / ₁₆	H	 Flow
250 – 300	R432 1 ¹⁵ / ₁₆ 3120 1 ⁷ / ₁₆	R362 2 ¹⁵ / ₁₆	R362 3 ¹¹ / ₁₆	D		35 – 40	1030 3 ⁷ / ₁₆ 3180 ①	R514 4 ⁷ / ₁₆ 3160 3 ³ / ₁₆	R3112 4 ¹⁵ / ₁₆ 3160 4 ⁷ / ₁₆	I	
200 – 250	R432 1 ¹⁵ / ₁₆ 3120 1 ⁷ / ₁₆	R362 2 ¹⁵ / ₁₆	R362 3 ¹¹ / ₁₆	D		30 – 35	R1035 3 ⁷ / ₁₆	1030 5 ¹⁵ / ₁₆ 3160 3 ³ / ₁₆	R514 5 ¹⁵ / ₁₆ 3160 4 ⁷ / ₁₆	I	
175 – 200	R432 1 ¹⁵ / ₁₆ 3140 1 ¹¹ / ₁₆	R362 2 ¹¹ / ₁₆	R362 3 ¹¹ / ₁₆	E		25 – 30	R1037 3 ¹⁵ / ₁₆	1030 5 ¹⁵ / ₁₆ 3180 3 ¹¹ / ₁₆	R514 5 ¹⁵ / ₁₆ 3160 4 ⁷ / ₁₆	J	
150 – 175	R432 1 ¹⁵ / ₁₆ 3140 1 ¹¹ / ₁₆	R362 2 ¹¹ / ₁₆ 3120 2 ³ / ₁₆	R362 3 ¹¹ / ₁₆	E		20 – 25	R1037 3 ¹⁵ / ₁₆	R1037 5 ⁷ / ₁₆ 3180 3 ¹¹ / ₁₆	1030 7 ¹ / ₂ 3160 4 ⁷ / ₁₆	K	
125 – 150	R778 3 ¹¹ / ₁₆ 3140 1 ¹¹ / ₁₆	R432 2 ¹¹ / ₁₆ 3120 2 ³ / ₁₆	R362 3 ¹¹ / ₁₆ 3120 3 ³ / ₁₆	E		17 1/2 – 20	AX1568 3 ¹¹ / ₁₆	R1037 5 ⁷ / ₁₆ 3180 3 ¹¹ / ₁₆	R1035 7 ¹ / ₂ 3180 4 ¹⁵ / ₁₆	K	
100 – 125	R588 3 ⁷ / ₁₆ 3160 1 ¹⁵ / ₁₆	R778 4 ¹⁵ / ₁₆ 3120 2 ³ / ₁₆	R432 3 ¹¹ / ₁₆ 3120 3 ³ / ₁₆	F		15 – 17 1/2	RX238 4 ⁷ / ₁₆	R1037 5 ⁷ / ₁₆ 3180 3 ¹¹ / ₁₆	R1037 8 3180 4 ¹⁵ / ₁₆	L	
90 – 100	R588 3 ⁷ / ₁₆ 3160 1 ¹⁵ / ₁₆	R778 4 ¹⁵ / ₁₆ 3140 2 ¹¹ / ₁₆	R432 3 ¹¹ / ₁₆ 3120 3 ³ / ₁₆	F		12 1/2 – 15	RX238 4 ⁷ / ₁₆	AX1568 5 ⁷ / ₁₆	R1037 8 3180 4 ¹⁵ / ₁₆	M	
80 – 90	R588 3 ⁷ / ₁₆ 3160 1 ¹⁵ / ₁₆	R778 4 ¹⁵ / ₁₆ 3140 2 ¹¹ / ₁₆	R778 4 ¹⁵ / ₁₆ 3120 3 ³ / ₁₆	F		10 – 12 1/2	RX238 4 ⁷ / ₁₆	RX238 7	AX1568 8 ¹ / ₂	N	
70 – 80	R514 2 ⁷ / ₁₆ 3180 2 ³ / ₁₆	R588 4 ¹⁵ / ₁₆ 3140 2 ¹¹ / ₁₆	R778 5 ⁷ / ₁₆ 3140 3 ¹⁵ / ₁₆	G		7 1/2 – 10	R1248 5 ⁷ / ₁₆	RX238 7	RX238 10	O	
60 – 70	R514 2 ⁷ / ₁₆ 3180 2 ³ / ₁₆	R588 4 ¹⁵ / ₁₆ 3140 2 ¹¹ / ₁₆	R778 5 ⁷ / ₁₆ 3140 3 ¹⁵ / ₁₆	G		5 – 7 1/2	RX1245 5 ⁷ / ₁₆	R1248 8	RX238 10	P	
50 – 60	R514 2 ⁷ / ₁₆ 3180 2 ³ / ₁₆	R3112 3 ⁷ / ₁₆ 3160 3 ³ / ₁₆	R588 5 ⁷ / ₁₆ 3140 3 ¹⁵ / ₁₆	G		4 – 5	RO635 5 ⁷ / ₁₆	RO635 9 ¹ / ₂	R1248 10	Q	
45 – 50	R514 2 ¹⁵ / ₁₆ 3180 ①	R3112 3 ⁷ / ₁₆ 3160 3 ³ / ₁₆	R588 5 ¹⁵ / ₁₆ 3140 3 ¹⁵ / ₁₆	H		3 – 4	RX1207 6 ¹ / ₂	RO635 9 ¹ / ₂	RX1245 10	R	
						2 – 3	RO1306 9	RX1207 ①	RO635 ①	S	
					1 – 2	X1307 9 ¹ / ₂	RO1306 ①	RX1207 ①	W		
					3/4 – 1	①	RO1306 ①	RO1306 ①	X		

Note: 1. 3100 Series chain operates over roller chain cut tooth sprockets.
2. Fabricated steel sprockets are recommended.





① Consult Rexnord

② Hub size letter – See page 79.

DESIGN AND SELECTION

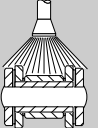
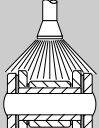
TABLE 2 (Cont'd.)
DRIVE CHAIN SELECTION TABLES

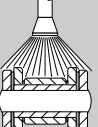
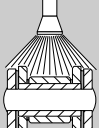
Note: Rex® drive chain selections are displayed in the tables. To interchange Link-Belt® and Rex chain numbers see pages 34-35.

Table 2 – (Cont'd.)											
RPM Driver Sprocket	DESIGN HORSEPOWER (DHP) = HP x SF For (SF) see pages 108-109				Type of Lubrication	RPM Driver Sprocket	DESIGN HORSEPOWER (DHP) = HP x SF For (SF) see pages 108-109				Type of Lubrication
	DRIVER SPROCKET – NO. OF TEETH LARGEST KEYSEATED BORE						DRIVER SPROCKET – NO. OF TEETH LARGEST KEYSEATED BORE				
	9T	12T	15T	Hub Letter [Ⓢ]			9T	12T	15T	Hub Letter [Ⓢ]	
15 DHP											
300 – 350	R432 1 ¹⁵ / ₁₆ 3140 1 ¹¹ / ₁₆	R432 2 ¹⁵ / ₁₆	R362 3 ¹¹ / ₁₆	D		40 – 45	R1037 3 ¹⁵ / ₁₆	1030 5 ¹⁵ / ₁₆ 3160 3 ³ / ₁₆	R514 5 ¹⁵ / ₁₆ 3160 4 ⁷ / ₁₆	J	
250 – 300	R432 1 ¹⁵ / ₁₆ 3140 1 ¹¹ / ₁₆	R432 2 ¹¹ / ₁₆	R362 3 ¹¹ / ₁₆	E		35 – 40	R1037 3 ¹⁵ / ₁₆	R1033 5 ¹⁵ / ₁₆ 3180 3 ¹¹ / ₁₆	1030 7 3160 4 ⁷ / ₁₆	J	
200 – 250	R778 3 ¹¹ / ₁₆ 3140 1 ¹¹ / ₁₆	R432 2 ¹¹ / ₁₆ 3120 2 ³ / ₁₆	R362 3 ¹¹ / ₁₆	E		30 – 35	R1037 3 ¹⁵ / ₁₆	R1037 5 ⁷ / ₁₆ 3180 3 ¹¹ / ₁₆	R1003 7 ¹ / ₂ 3160 4 ⁷ / ₁₆	K	
175 – 200	R588 3 ¹¹ / ₁₆ 3160 1 ¹⁵ / ₁₆	R432 2 ¹¹ / ₁₆ 3120 2 ³ / ₁₆	R432 3 ¹¹ / ₁₆	E		25 – 30	AX1568 3 ¹¹ / ₁₆	R1037 5 ⁷ / ₁₆ 3180 3 ¹¹ / ₁₆	R1037 7 ¹ / ₂ 3180 4 ¹⁵ / ₁₆	K	
150 – 175	R588 3 ⁷ / ₁₆ 3160 1 ¹⁵ / ₁₆	R778 4 ¹⁵ / ₁₆ 3120 2 ³ / ₁₆	R432 3 ¹¹ / ₁₆ 3120 3 ³ / ₁₆	F		20 – 25	RX238 4 ⁷ / ₁₆	AX1568 5 ⁷ / ₁₆	R1037 8 3180 4 ¹⁵ / ₁₆	L	
125 – 150	R3112 2 ³ / ₁₆ 3160 1 ¹⁵ / ₁₆	R778 4 ¹⁵ / ₁₆ 3120 2 ³ / ₁₆	R432 3 ¹¹ / ₁₆ 3120 3 ³ / ₁₆	F		17 ¹ / ₂ – 20	RX238 4 ⁷ / ₁₆	RX238 7	R1037 8	M	
100 – 125	R514 2 ⁷ / ₁₆ 3160 2 ³ / ₁₆	R588 4 ¹⁵ / ₁₆ 3140 2 ¹¹ / ₁₆	R788 5 ⁷ / ₁₆ 3120 3 ³ / ₁₆	G		15 – 17 ¹ / ₂	R1248 4 ⁷ / ₁₆	RX238 7	AX1568 8 ¹ / ₂	N	
90 – 100	R514 2 ⁷ / ₁₆ 3180 2 ³ / ₁₆	R588 4 ¹⁵ / ₁₆ 3140 2 ¹¹ / ₁₆	R788 5 ⁷ / ₁₆ 3140 3 ¹⁵ / ₁₆	G		12 ¹ / ₂ – 15	R1248 5 ⁷ / ₁₆	RX238 7	RX238 10	O	
80 – 90	R514 2 ⁷ / ₁₆ 3180 2 ³ / ₁₆	R3112 3 ⁷ / ₁₆ 3140 2 ¹ / ₁₆	R588 5 ⁷ / ₁₆ 3140 3 ¹⁵ / ₁₆	G		10 – 12 ¹ / ₂	RX1245 5 ⁷ / ₁₆	R1248 8	RX238 10	O	
70 – 80	R514 2 ¹⁵ / ₁₆ 3180 ①	R3112 3 ⁷ / ₁₆ 3140 2 ¹ / ₁₆	R588 5 ¹⁵ / ₁₆ 3140 3 ¹⁵ / ₁₆	H		7 ¹ / ₂ – 10	RO635 5 ⁷ / ₁₆	RX1245 8	R1248 10	P	
60 – 70	1030 3 ¹¹ / ₁₆ 3180 ①	R3112 3 ⁷ / ₁₆ 3160 3 ⁷ / ₁₆	R3112 4 ¹⁵ / ₁₆ 3140 3 ¹⁵ / ₁₆	H		5 – 7 ¹ / ₂	RX1207 6 ¹ / ₂	RO635 9 ¹ / ₂	RX1245 10	Q	
50 – 60	R1033 3 ¹¹ / ₁₆	R514 4 ⁷ / ₁₆ 3160 3 ³ / ₁₆	R3112 4 ¹⁵ / ₁₆ 3160 4 ⁷ / ₁₆	I		4 – 5	RO1306 9	RO635 9 ¹ / ₂	RO635 ①	R	
45 – 50	R1037 3 ³ / ₁₆	1030 5 ¹⁵ / ₁₆ 3160 3 ³ / ₁₆	R514 5 ¹⁵ / ₁₆ 3160 4 ⁷ / ₁₆	I		3 – 4	RO1306 9	RX1207 ①	RO635 ①	S	
						2 – 3	X1307 10	RO1306 ①	RX1207 ①	U	
					1 – 2	①	RO1306 ①	RO1306 ①	Y		
					3/4 – 1	①	RO1306 ①	RO1306 ①	Z		
					1/2 – 3/4	①	①	X1307 ①	①		
20 DHP											
300 – 350	R514 2 ¹⁵ / ₁₆ 3160 1 ¹⁵ / ₁₆	R432 2 ¹⁵ / ₁₆ 3120 2 ³ / ₁₆	R432 3 ¹¹ / ₁₆	E		40 – 50	R1037 3 ¹⁵ / ₁₆	R035 5 ⁷ / ₁₆ 3180 3 ¹¹ / ₁₆	1030 7 3160 4 ⁷ / ₁₆	J	
250 – 300	R514 2 ¹⁵ / ₁₆ 3160 1 ¹⁵ / ₁₆	R432 2 ¹¹ / ₁₆ 3120 2 ³ / ₁₆	R342 3 ¹¹ / ₁₆ 3120 3 ³ / ₁₆	E		40 – 45	R1037 3 ¹⁵ / ₁₆	R1037 5 ⁷ / ₁₆ 3180 3 ¹¹ / ₁₆	R1033 7 ¹ / ₂ 3180 4 ¹⁵ / ₁₆	K	
200 – 250	R514 2 ¹¹ / ₁₆ 3160 1 ¹⁵ / ₁₆	R778 4 ¹⁵ / ₁₆ 3120 2 ³ / ₁₆	R432 3 ¹¹ / ₁₆ 3120 3 ³ / ₁₆	F		35 – 40	AX1568 3 ¹¹ / ₁₆	R1037 5 ⁷ / ₁₆ 3180 3 ¹¹ / ₁₆	R1035 7 ¹ / ₂ 3180 4 ¹⁵ / ₁₆	K	
175 – 200	R514 2 ¹¹ / ₁₆ 3160 1 ¹⁵ / ₁₆	R778 4 ¹⁵ / ₁₆ 3120 2 ³ / ₁₆	R432 3 ¹¹ / ₁₆ 3120 3 ³ / ₁₆	F		30 – 35	RX236 4 ⁷ / ₁₆	R1037 5 ⁷ / ₁₆	R1037 8 3180 4 ¹⁵ / ₁₆	L	
150 – 175	R514 2 ¹¹ / ₁₆ 3180 2 ³ / ₁₆	R778 4 ¹⁵ / ₁₆ 3140 2 ¹¹ / ₁₆	R778 4 ¹⁵ / ₁₆ 3120 3 ³ / ₁₆	F		25 – 30	RX238 4 ⁷ / ₁₆	AX1568 5 ⁷ / ₁₆	R1037 8	M	
125 – 150	R514 2 ⁷ / ₁₆ 3180 2 ³ / ₁₆	R3112 3 ⁷ / ₁₆ 3140 1 ¹¹ / ₁₆	R778 5 ⁷ / ₁₆ 3140 3 ¹⁵ / ₁₆	G		20 – 25	R1248 4 ⁷ / ₁₆	RX238 7	AX1568 8 ¹ / ₂	N	
100 – 125	R514 2 ⁷ / ₁₆ 3180 2 ³ / ₁₆	R3112 3 ⁷ / ₁₆ 3140 2 ¹ / ₁₆	R588 5 ⁷ / ₁₆ 3140 3 ¹⁵ / ₁₆	G		17 ¹ / ₂ – 20	R1248 5 ⁷ / ₁₆	RX238 7	RX238 10	O	
90 – 100	R514 2 ¹⁵ / ₁₆ 3180 ①	R3112 3 ⁷ / ₁₆ 3160 3 ³ / ₁₆	R588 5 ¹⁵ / ₁₆ 3140 3 ¹⁵ / ₁₆	H		15 – 17 ¹ / ₂	RX1245 5 ⁷ / ₁₆	R1248 8	RX238 10	O	
80 – 90	1030 3 ¹¹ / ₁₆	R3112 3 ⁷ / ₁₆ 3160 3 ³ / ₁₆	R3112 4 ¹⁵ / ₁₆ 3160 4 ⁷ / ₁₆	H		12 ¹ / ₂ – 15	RO635 5 ⁷ / ₁₆	R1248 8	RX238 10	O	
70 – 80	R1033 3 ¹¹ / ₁₆	1030 5 ¹⁵ / ₁₆ 3160 3 ³ / ₁₆	R3112 4 ¹⁵ / ₁₆ 3160 4 ⁷ / ₁₆	I		10 – 12 ¹ / ₂	RO635 5 ⁷ / ₁₆	RX1245 8	RX1248 10	O	
60 – 70	R1037 3 ³ / ₁₆	1030 5 ¹⁵ / ₁₆ 3160 3 ³ / ₁₆	R514 5 ¹⁵ / ₁₆ 3160 4 ⁷ / ₁₆	I		7 ¹ / ₂ – 10	RX1207 6 ¹ / ₂	RO635 9 ¹ / ₂	RO635 ①	Q	
50 – 60	R1037 3 ¹⁵ / ₁₆	R1033 5 ¹⁵ / ₁₆ 3180 3 ¹¹ / ₁₆	1030 7 3160 4 ⁷ / ₁₆	J		5 – 7 ¹ / ₂	RO1306 9	RO635 9 ¹ / ₂	RO635 ①	S	
						4 – 5	RO1306 9	RX1207 ①	RX1207 ①	S	
						3 – 4	X1307 10	RO1306 ①	RX1207 ①	U	
					2 – 3	X1307 9 ¹ / ₂	RO1306 ①	RO1306 ①	W		
					1 – 2	①	X1307 ①	RO1307 ①	Z		

Note: 1. 3100 Series chain operates over roller chain cut tooth sprockets.
2. Fabricated steel sprockets are recommended.

① Consult Rexnord

② Hub size letter – See page 79.

DESIGN AND SELECTION

TABLE 2 (Cont'd.)
DRIVE CHAIN SELECTION TABLES

Note: Rex® drive chain selections are displayed in the tables. To interchange Link-Belt® and Rex chain numbers see pages 34-35.

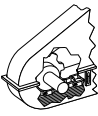
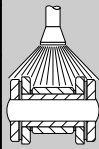
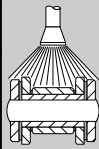
Table 2 – (Cont'd.)											
RPM Driver Sprocket	DESIGN HORSEPOWER (DHP) = HP x SF For (SF) see pages 108-109				Type of Lubrication	RPM Driver Sprocket	DESIGN HORSEPOWER (DHP) = HP x SF For (SF) see pages 108-109				Type of Lubrication
	DRIVER SPROCKET – NO. OF TEETH LARGEST KEYSEATED BORE						DRIVER SPROCKET – NO. OF TEETH LARGEST KEYSEATED BORE				
	9T	12T	15T	Hub Letter ²			9T	12T	15T	Hub Letter ²	
25 DHP											
300 – 350	R3112 2 ³ / ₁₆ 3160 1 ¹⁵ / ₁₆	R432 2 ¹¹ / ₁₆ 3120 2 ³ / ₁₆	R432 3 ¹¹ / ₁₆	E	 Oil Bath	50 – 60	R1037 3 ¹⁵ / ₁₆	R1037 5 ⁷ / ₁₆ 3180 3 ¹¹ / ₁₆	R1033 7 ¹ / ₂ 3180 4 ¹⁵ / ₁₆	K	 Flow
250 – 300	R3112 2 ³ / ₁₆ 3160 1 ¹⁵ / ₁₆	R778 4 ¹⁵ / ₁₆ 3120 2 ³ / ₁₆	R432 3 ¹¹ / ₁₆ 3120 3 ³ / ₁₆	F		45 – 50	AX1568 3 ¹¹ / ₁₆	R1037 5 ⁷ / ₁₆ 3180 3 ¹¹ / ₁₆	R1035 7 ¹ / ₂ 3180 4 ¹⁵ / ₁₆	K	
200 – 250	R3112 2 ³ / ₁₆ 3180 2 ³ / ₁₆	R588 4 ¹⁵ / ₁₆ 3140 2 ¹¹ / ₁₆	R788 4 ¹⁵ / ₁₆ 3120 3 ³ / ₁₆	F		40 – 45	RX238 4 ⁷ / ₁₆	R1037 5 ⁷ / ₁₆	R1037 8 3180 4 ¹⁵ / ₁₆	L	
175 – 200	R514 2 ⁷ / ₁₆ 3180 2 ³ / ₁₆	R3112 3 ⁷ / ₁₆ 3140 2 ¹¹ / ₁₆	R778 5 ⁷ / ₁₆ 3120 3 ³ / ₁₆	G		35 – 40	RX238 4 ⁷ / ₁₆	R1037 5 ⁷ / ₁₆	R1037 8	L	
150 – 175	R514 2 ⁷ / ₁₆ 3180 2 ³ / ₁₆	R3112 3 ⁷ / ₁₆ 3140 2 ¹¹ / ₁₆	R778 5 ⁷ / ₁₆ 3140 3 ¹⁵ / ₁₆	G		30 – 35	RX238 4 ⁷ / ₁₆	AX1568 5 ⁷ / ₁₆	R1037 8	M	
125 – 150	R514 2 ⁷ / ₁₆ 3180 2 ³ / ₁₆	R3112 3 ⁷ / ₁₆ 3160 3 ³ / ₁₆	R588 5 ⁷ / ₁₆ 3140 3 ¹⁵ / ₁₆	G		25 – 30	R1248 4 ⁷ / ₁₆	RX238 7	AX1568 8 ¹ / ₂	N	
100 – 125	1030 3 ¹¹ / ₁₆	R3112 3 ⁷ / ₁₆ 3160 3 ³ / ₁₆	R3112 3 ⁷ / ₁₆ 3140 3 ¹⁵ / ₁₆	H		20 – 25	RX1245 5 ⁷ / ₁₆	RX238 7	RX238 10	O	
90 – 100	R1030 3 ¹⁵ / ₁₆	R514 4 ⁷ / ₁₆ 3160 3 ³ / ₁₆	R3112 4 ¹⁵ / ₁₆ 3160 4 ⁷ / ₁₆	I		17 ¹ / ₂ – 20	RO635 5 ⁷ / ₁₆	R1248 8	RX238 10	O	
80 – 90	R1037 3 ³ / ₁₆	1030 5 ¹⁵ / ₁₆ 3160 3 ³ / ₁₆	R3112 4 ¹⁵ / ₁₆ 3160 4 ⁷ / ₁₆	I		15 – 17 ¹ / ₂	RO635 5 ⁷ / ₁₆	R1248 8	R1238 10	P	
70 – 80	R1037 3 ³ / ₁₆	1030 5 ¹⁵ / ₁₆ 3180 3 ¹¹ / ₁₆	R514 5 ¹⁵ / ₁₆ 3160 4 ⁷ / ₁₆	I		12 ¹ / ₂ – 15	RO635 5 ⁷ / ₁₆	RO635 9 ¹ / ₂	R1248 10	P	
60 – 70	R1037 3 ¹⁵ / ₁₆	R1033 5 ¹⁵ / ₁₆ 3180 3 ¹¹ / ₁₆	1030 7 3160 4 ⁷ / ₁₆	J	10 – 12 ¹ / ₂	RX1207 6 ¹ / ₂	RO635 9 ¹ / ₂	RO635 10	Q		
30 DHP											
300 – 350	R3112 2 ³ / ₁₆ 3180 2 ³ / ₁₆	R3112 3 ⁷ / ₁₆ 3140 2 ¹¹ / ₁₆	R432 3 ¹¹ / ₁₆ 3120 3 ³ / ₁₆	F	 Oil Bath	50 – 60	AX1568 3 ¹¹ / ₁₆	R1037 5 ⁷ / ₁₆	R1037 7 ¹ / ₂ 3180 4 ¹⁵ / ₁₆	K	 Flow
250 – 300	R3112 2 ³ / ₁₆ 3180 2 ³ / ₁₆	R3112 3 ⁷ / ₁₆ 3140 2 ¹¹ / ₁₆	R432 3 ¹¹ / ₁₆ 3120 3 ³ / ₁₆	F		45 – 50	RX238 4 ⁷ / ₁₆	R1037 5 ⁷ / ₁₆	R1037 8 3180 4 ¹⁵ / ₁₆	L	
200 – 250	R514 2 ⁷ / ₁₆ 3180 2 ³ / ₁₆	R3112 3 ⁷ / ₁₆ 3160 3 ³ / ₁₆	R788 5 ⁷ / ₁₆ 3140 3 ¹⁵ / ₁₆	G		40 – 45	RX238 4 ⁷ / ₁₆	AX1568 5 ⁷ / ₁₆	R1037 8	L	
175 – 200	R514 2 ⁷ / ₁₆ 3180 2 ³ / ₁₆	R3112 3 ⁷ / ₁₆ 3160 3 ³ / ₁₆	R588 5 ⁷ / ₁₆ 3140 3 ¹⁵ / ₁₆	G		35 – 40	RX238 4 ⁷ / ₁₆	RX238 7	R1037 8	M	
150 – 175	R415 2 ⁷ / ₁₆	R3112 3 ⁷ / ₁₆ 3160 3 ³ / ₁₆	R588 5 ⁷ / ₁₆ 3140 3 ¹⁵ / ₁₆	G		30 – 35	R1248 4 ⁷ / ₁₆	RX238 7	AX1568 8 ¹ / ₂	N	
125 – 150	1030 3 ¹¹ / ₁₆	R3112 3 ⁷ / ₁₆ 3160 3 ³ / ₁₆	R3112 4 ¹⁵ / ₁₆ 3140 3 ¹⁵ / ₁₆	H		25 – 30	R1248 5 ⁷ / ₁₆	RX238 7	RX238 10	O	
100 – 125	R1035 3 ⁷ / ₁₆	1030 5 ¹⁵ / ₁₆ 3160 3 ³ / ₁₆	R3112 4 ¹⁵ / ₁₆ 3160 4 ⁷ / ₁₆	I		20 – 25	RO635 5 ⁷ / ₁₆	R1248 8	RX238 10	O	
90 – 100	R1037 3 ³ / ₁₆	1030 5 ¹⁵ / ₁₆ 3180 3 ¹¹ / ₁₆	R514 5 ¹⁵ / ₁₆ 3160 4 ⁷ / ₁₆	I		17 ¹ / ₂ – 20	RO635 5 ⁷ / ₁₆	RX1245 8	R1248 10	P	
80 – 90	R1037 3 ¹⁵ / ₁₆	1030 5 ¹⁵ / ₁₆ 3180 3 ¹¹ / ₁₆	1030 7 3160 4 ⁷ / ₈	J		15 – 17 ¹ / ₂	RO635 5 ⁷ / ₁₆	RO635 9 ¹ / ₂	R1248 10	P	
70 – 80	R1037 3 ¹⁵ / ₁₆	R1035 5 ⁷ / ₁₆ 3180 3 ¹¹ / ₁₆	1030 7 3160 4 ⁷ / ₁₆	J		12 ¹ / ₂ – 15	RX1207 6 ¹ / ₂	RO635 9 ¹ / ₂	RX1245 10	Q	
60 – 70	R1037 3 ¹⁵ / ₁₆	R1037 5 ⁷ / ₁₆ 3180 3 ¹¹ / ₁₆	R1033 7 ¹ / ₂ 3180 4 ¹⁵ / ₁₆	K	10 – 12 ¹ / ₂	RX1207 6 ¹ / ₂	RO635 9 ¹ / ₂	RO635 10	Q		
Manual Lubrication											
80 – 90	R1037 3 ¹⁵ / ₁₆	1030 5 ¹⁵ / ₁₆ 3180 3 ¹¹ / ₁₆	1030 7 3160 4 ⁷ / ₈	J	7 ¹ / ₂ – 10	RO1306 9	RX1207 10	RO635 10	Q		
70 – 80	R1037 3 ¹⁵ / ₁₆	R1035 5 ⁷ / ₁₆ 3180 3 ¹¹ / ₁₆	1030 7 3160 4 ⁷ / ₁₆	J	5 – 7 ¹ / ₂	X1307 10	RO1306 10	RX1207 10	T		
60 – 70	R1037 3 ¹⁵ / ₁₆	R1037 5 ⁷ / ₁₆ 3180 3 ¹¹ / ₁₆	R1033 7 ¹ / ₂ 3180 4 ¹⁵ / ₁₆	K	4 – 5	X1307 10	RO1306 10	RO1306 10	U		
Flow Lubrication											
60 – 70	R1037 3 ¹⁵ / ₁₆	R1037 5 ⁷ / ₁₆ 3180 3 ¹¹ / ₁₆	R1033 7 ¹ / ₂ 3180 4 ¹⁵ / ₁₆	K	3 – 4	X1307 9 ¹ / ₂	RO1306 10	RX1306 10	W		
Manual Lubrication											
60 – 70	R1037 3 ¹⁵ / ₁₆	R1037 5 ⁷ / ₁₆ 3180 3 ¹¹ / ₁₆	R1033 7 ¹ / ₂ 3180 4 ¹⁵ / ₁₆	K	2 – 3	10	X1307 10	RO1306 10	Y		

Note: 1. 3100 Series chain operates over roller chain cut tooth sprockets.
2. Fabricated steel sprockets are recommended.





© Consult Rexnord

© Hub size letter – See page 79.

DESIGN AND SELECTION

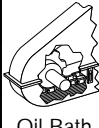
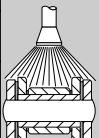
**TABLE 2 (Cont'd.)
DRIVE CHAIN SELECTION TABLES**

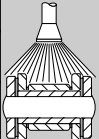
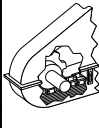
Note: Rex® drive chain selections are displayed in the tables. To interchange Link-Belt® and Rex chain numbers see pages 34-35.

Table 2 – (Cont'd.)													
RPM Driver Sprocket	DESIGN HORSEPOWER (DHP) = HP x SF For (SF) see pages 108-109					Type of Lubrication	RPM Driver Sprocket	DESIGN HORSEPOWER (DHP) = HP x SF For (SF) see pages 108-109					Type of Lubrication
	DRIVER SPROCKET – NO. OF TEETH LARGEST KEYSEATED BORE							DRIVER SPROCKET – NO. OF TEETH LARGEST KEYSEATED BORE					
	9T	12T	15T	Hub Letter®				9T	12T	15T	Hub Letter®		
35 DHP													
300 – 350	R514 2 ¹¹ / ₁₆ 3180 2 ³ / ₁₆	R3112 3 ⁷ / ₁₆ 3140 2 ¹¹ / ₁₆	R432 3 ¹¹ / ₁₆ 3120 3 ³ / ₁₆	F	 Oil Bath	50 – 60	RX238 4 ⁷ / ₁₆	R1037 5 ⁷ / ₁₆	R1037 8 3180 4 ⁵ / ₁₆	L	 Flow		
250 – 300	R514 2 ⁷ / ₁₆ 3180 2 ³ / ₁₆	R3112 3 ⁷ / ₁₆ 3160 3 ³ / ₁₆	R3112 4 ⁵ / ₁₆ 3140 3 ⁵ / ₁₆	G		45 – 50	RX238 4 ⁷ / ₁₆	AX1568 5 ⁷ / ₁₆	R1037 8	M			
200 – 250	R514 2 ⁷ / ₁₆ 3180 2 ³ / ₁₆	R3112 3 ⁷ / ₁₆ 3160 3 ³ / ₁₆	R3112 4 ⁵ / ₁₆ 3140 3 ⁵ / ₁₆	G		40 – 45	RX238 4 ⁷ / ₁₆	RX238 7	R1037 8	M			
175 – 200	R514 2 ⁷ / ₁₆	R3112 3 ⁷ / ₁₆ 3160 3 ³ / ₁₆	R3112 4 ⁵ / ₁₆ 3140 3 ⁵ / ₁₆	G		35 – 40	R1248 4 ⁷ / ₁₆	RX238 7	AX1568 8 ¹ / ₂	N			
150 – 175	1030 3 ¹¹ / ₁₆	R3112 3 ⁷ / ₁₆ 3160 3 ³ / ₁₆	R3112 4 ⁵ / ₁₆ 3140 3 ⁵ / ₁₆	H		30 – 35	R1248 5 ⁷ / ₁₆	RX238 7	RX238 10	O			
125 – 150	R1035 3 ⁷ / ₁₆	1030 5 ⁵ / ₁₆ 3160 3 ³ / ₁₆	R3112 4 ⁵ / ₁₆ 3160 4 ⁷ / ₁₆	I		25 – 30	RX1245 5 ⁷ / ₁₆	R1248 8	RX238 10	O			
100 – 125	R1037 3 ³ / ₁₆	1030 5 ⁵ / ₁₆ 3180 3 ¹¹ / ₁₆	R514 5 ⁵ / ₁₆ 3160 4 ⁷ / ₁₆	I		20 – 25	RO635 5 ⁷ / ₁₆	R1248 8	R1248 10	P			
90 – 100	R1037 3 ⁵ / ₁₆	R1033 5 ⁵ / ₁₆ 3180 3 ¹¹ / ₁₆	1030 7 3160 4 ⁷ / ₁₆	J		17 ¹ / ₂ – 20	RO635 5 ⁷ / ₁₆	RO635 9 ¹ / ₂	R1248 10	P			
80 – 90	R1037 3 ⁵ / ₁₆	R1035 5 ⁷ / ₁₆ 3180 3 ¹¹ / ₁₆	1030 7 3160 4 ⁷ / ₁₆	J		15 – 17 ¹ / ₂	RX1207 6 ¹ / ₂	RO635 9 ¹ / ₂	RO635 ①	Q			
70 – 80	R1037 3 ⁵ / ₁₆	R1037 5 ⁷ / ₁₆ 3180 3 ¹¹ / ₁₆	R1033 7 ¹ / ₂ 3180 4 ⁵ / ₁₆	K		12 ¹ / ₂ – 15	RX1207 6 ¹ / ₂	RO635 9 ¹ / ₂	RO635 ①	Q			
60 – 70	RX238 4 ⁷ / ₁₆	R1037 5 ⁷ / ₁₆	R1035 7 ¹ / ₂ 3180 4 ⁵ / ₁₆	K	10 – 12 ¹ / ₂	RO1306 9	RX1207 ①	RO635 ①	R				
					7 ¹ / ₂ – 10	RO1306 9	RX1207 ①	RX1207 ①	S				
					5 – 7 ¹ / ₂	X1307 10	RO1306 ①	RO1306 ①	U				
					4 – 5	X1307 9 ¹ / ₂	RO1306 ①	RO1306 ①	V				
					3 – 4	①	RO1306 ①	RO1306 ①	X				
					2 – 3	①	①	X1307 ①	Z				
40 DHP													
300 – 350	R514 2 ¹¹ / ₁₆ 3180 2 ³ / ₁₆	R3112 3 ⁷ / ₁₆ 3140 2 ¹¹ / ₁₆	R3112 4 ⁵ / ₁₆ 3120 3 ³ / ₁₆	F	 Oil Bath	60 – 70	RX238 4 ⁷ / ₁₆	R1037 5 ⁷ / ₁₆	R1037 8 3180 4 ¹⁵ / ₁₆	L	 Flow		
250 – 300	R514 2 ⁷ / ₁₆ 3180 2 ³ / ₁₆	R3112 3 ⁷ / ₁₆ 3160 3 ³ / ₁₆	R3112 4 ⁵ / ₁₆ 3140 3 ⁵ / ₁₆	G		50 – 60	RX238 4 ⁷ / ₁₆	AX1568 5 ⁷ / ₁₆	R1037 8	M			
200 – 250	R514 2 ⁷ / ₁₆	R3112 3 ⁷ / ₁₆ 3160 3 ³ / ₁₆	R3112 4 ⁵ / ₁₆ 3140 3 ⁵ / ₁₆	G		45 – 50	RX238 4 ⁷ / ₁₆	RX238 7	R1037 8	M			
175 – 200	R514 2 ⁵ / ₁₆	1030 5 ⁵ / ₁₆ 3160 3 ³ / ₁₆	R3112 4 ⁵ / ₁₆ 3140 3 ⁵ / ₁₆	H		40 – 45	R1248 4 ⁷ / ₁₆	RX238 7	AX1568 8 ¹ / ₂	N			
150 – 175	R1033 3 ⁵ / ₁₆	1030 5 ⁵ / ₁₆ 3160 3 ³ / ₁₆	R3112 4 ⁵ / ₁₆ 3160 4 ⁷ / ₁₆	H		35 – 40	R1248 5 ⁷ / ₁₆	RX238 7	RX238 10	O			
125 – 150	R1037 3 ⁷ / ₁₆	1030 5 ⁵ / ₁₆ 3180 3 ¹¹ / ₁₆	R3112 4 ⁵ / ₁₆ 3160 4 ⁷ / ₁₆	I		30 – 35	RX1245 5 ⁷ / ₁₆	R1248 8	RX238 10	O			
100 – 125	R1037 3 ⁵ / ₁₆	R1033 5 ⁵ / ₁₆ 3180 3 ¹¹ / ₁₆	1030 7 3160 4 ⁷ / ₁₆	J		25 – 30	RO635 5 ⁷ / ₁₆	R1248 8	RX238 10	O			
90 – 100	R1037 3 ⁵ / ₁₆	R1035 5 ⁷ / ₁₆ 3180 3 ¹¹ / ₁₆	1030 7 3180 4 ⁵ / ₁₆	J		20 – 25	RO635 5 ⁷ / ₁₆	RO635 9 ¹ / ₂	R1248 10	P			
80 – 90	R1037 3 ⁵ / ₁₆	R1037 5 ⁷ / ₁₆	R1033 7 ¹ / ₂ 3180 4 ⁵ / ₁₆	K		17 ¹ / ₂ – 20	RX1207 6 ¹ / ₂	RX635 9 ¹ / ₂	RX1245 10	Q			
70 – 80	AX1568 3 ¹¹ / ₁₆	R1037 5 ⁷ / ₁₆	R1035 8 3180 4 ⁵ / ₁₆	L		15 – 17 ¹ / ₂	RX1207 6 ¹ / ₂	RO635 9 ¹ / ₂	RO635 ①	Q			
					12 ¹ / ₂ – 15	RX1207 6 ¹ / ₂	RX1207 ①	RO635 ①	R				
					10 – 12 ¹ / ₂	RO1306 9	RX1207 ①	RX1207 ①	S				
					7 ¹ / ₂ – 10	RO1306 9	RX1306 ①	RX1207 ①	T				
					5 – 7 ¹ / ₂	X1307 10	RO1306 ①	RO1306 ①	U				
					4 – 5	X1307 9 ¹ / ₂	RO1306 ①	RO1306 ①	W				
					2 – 3	①	RO1306 ①	RO1306 ①	X				
45 DHP													
300 – 350	R514 2 ⁷ / ₁₆ 3180 2 ³ / ₁₆	R3112 3 ⁷ / ₁₆ 3160 3 ³ / ₁₆	R3112 4 ⁵ / ₁₆ 3140 3 ⁵ / ₁₆	G	 Oil Bath	175 – 200	R1033 3 ⁵ / ₁₆	1033 5 ⁵ / ₁₆ 3160 3 ³ / ₁₆	R3112 4 ⁵ / ₁₆ 3140 3 ⁵ / ₁₆	H	 Oil Bath		
250 – 300	R514 2 ⁷ / ₁₆	R3112 3 ⁷ / ₁₆ 3160 3 ³ / ₁₆	R3112 4 ⁵ / ₁₆ 3140 3 ⁵ / ₁₆	G		150 – 175	R1037 3 ³ / ₁₆	1030 5 ⁵ / ₁₆ 3180 3 ¹¹ / ₁₆	R3112 4 ⁵ / ₁₆ 3160 4 ⁷ / ₁₆	I			
200 – 250	R1033 3 ⁵ / ₁₆	1030 5 ⁵ / ₁₆ 3160 3 ³ / ₁₆	R3112 4 ⁵ / ₁₆ 3140 3 ⁵ / ₁₆	H		125 – 150	R1037 3 ⁷ / ₁₆	R1033 5 ⁵ / ₁₆ 3180 3 ¹¹ / ₁₆	1030 6 ¹ / ₂ 3160 4 ⁷ / ₁₆	I			

Note: 1. 3100 Series chain operates over roller chain cut tooth sprockets.
2. Fabricated steel sprockets are recommended.







① Consult Rexnord

② Hub size letter – See page 79.

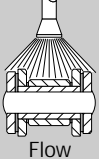
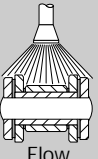
DESIGN AND SELECTION

TABLE 2 (Cont'd.) DRIVE CHAIN SELECTION TABLES

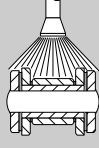
Note: Rex® drive chain selections are displayed in the tables. To interchange Link-Belt® and Rex chain numbers see pages 34-35.

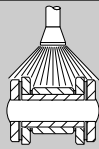
Table 2 – (Cont'd.)											
RPM Driver Sprocket	DESIGN HORSEPOWER (DHP) = HP x SF For (SF) see pages 108-109				Type of Lubrication	RPM Driver Sprocket	DESIGN HORSEPOWER (DHP) = HP x SF For (SF) see pages 108-109				Type of Lubrication
	DRIVER SPROCKET – NO. OF TEETH LARGEST KEYSEATED BORE						DRIVER SPROCKET – NO. OF TEETH LARGEST KEYSEATED BORE				
	9T	12T	15T	Hub Letter ²			9T	12T	15T	Hub Letter ²	
45 DHP – Cont'd.											
100 – 125	R1037 3 ^{15/16}	R1035 5 ^{7/16} 3180 3 ^{11/16}	R1033 7 3180 4 ^{15/16}	J		30 – 35	RO635 5 ^{7/16}	R1248 8	RX238 10	O	
90 – 100	AX1568 3 ^{11/16}	R1037 5 ^{7/16}	R1033 7 ^{1/2} 3180 4 ^{15/16}	K		35 – 30	RO635 5 ^{7/16}	RX1245 8	RX1248 10	P	
80 – 90	RX238 4 ^{7/16}	R1037 5 ^{7/16}	R1035 7 ^{1/2} 3180 4 ^{15/16}	K		20 – 25	RX1207 6 ^{1/2}	RO635 9 ^{1/2}	RX1245 10	Q	
70 – 80	RX238 4 ^{7/16}	R1037 5 ^{7/16}	1037 8	L		17 ^{1/2} – 20	RX1207 6 ^{1/2}	RO635 9 ^{1/2}	RO635 ①	Q	
60 – 70	RX238 4 ^{7/16}	AX1568 5 ^{7/16}	1037 8	L		15 – 17 ^{1/2}	RX1207 6 ^{1/2}	RO635 9 ^{1/2}	RO635 ①	Q	
50 – 60	R1248 4 ^{7/16}	RX238 7	1037 8	M		12 ^{1/2} – 15	RO1036 9	RX1207 ①	RO635 ①	R	
45 – 50	R1248 4 ^{7/16}	RX238 7	AX1568 8 ^{1/2}	N		10 – 12 ^{1/2}	RO1036 9	RX1207 ①	RX1027 ①	S	
40 – 45	R1248 4 ^{7/16}	RX238 7	RX238 10	N		7 ^{1/2} – 10	X1307 10	RO1306 ①	RX1027 ①	T	
35 – 40	RX1245 5 ^{7/16}	R1248 8	RX238 10	O	5 – 7 ^{1/2}	X1307 9 ^{1/2}	RO1306 ①	RO1306 ①	V		
					4 – 5	①	RO1306 ①	RO1306 ①	W		
						3 – 4	①	RO1306 ①	Y		
50 DHP											
300 – 350	R514 2 ^{7/16}	R514 4 ^{7/16} 3160 3 ^{3/16}	R3112 4 ^{15/16} 3140 3 ^{15/16}	G		60 – 70	RX238 4 ^{7/16}	RX238 7	R1037 8	M	
250 – 300	R1035 3 ^{15/16}	R514 4 ^{7/16} 3160 3 ^{3/16}	R3112 4 ^{15/16} 3140 3 ^{15/16}	G		50 – 60	R1248 4 ^{7/16}	RX238 7	AX1568 8 ^{1/2}	N	
200 – 250	R1035 3 ^{11/16}	1030 5 ^{15/16} 3160 3 ^{3/16}	R3112 4 ^{15/16} 3140 3 ^{15/16}	H		45 – 50	R1248 4 ^{7/16}	RX238 7	RX238 9	N	
175 – 200	R1037 3 ^{7/16}	R1033 5 ^{15/16} 3180 3 ^{11/16}	R3112 4 ^{15/16} 3160 4 ^{7/16}	I		40 – 45	RX1245 5 ^{7/16}	RX238 7	RX238 9 ^{1/2}	O	
150 – 175	R1037 3 ^{7/16}	R1033 5 ^{15/16} 3180 3 ^{11/16}	1033 6 ^{1/2} 3160 4 ^{7/16}	I		35 – 40	RO635 5 ^{7/16}	R1248 8	RX238 9 ^{1/2}	O	
125 – 150	R1037 3 ^{15/16}	R1033 5 ^{15/16} 3180 3 ^{11/16}	1030 7 3160 4 ^{7/16}	J		30 – 35	RO635 5 ^{7/16}	RX1245 8	R1248 10	P	
100 – 125	R1037 3 ^{15/16}	R1037 5 ^{7/16} 3180 3 ^{11/16}	R1033 7 ^{1/2} 3180 4 ^{15/16}	K		25 – 30	RO635 5 ^{7/16}	RO635 9 ^{1/2}	R1248 10	P	
90 – 100	AX1568 3 ^{11/16}	R1037 5 ^{7/16}	R1035 7 ^{1/2} 3180 4 ^{15/16}	K		20 – 25	RX1207 6 ^{1/2}	RO635 9 ^{1/2}	RO635 ①	Q	
80 – 90	RX238 4 ^{7/16}	R1037 5 ^{7/16}	1037 8 3180 4 ^{15/16}	L		17 ^{1/2} – 20	RX1207 6 ^{1/2}	RO635 9 ^{1/2}	RO635 ①	Q	
70 – 80	RX238 4 ^{7/16}	R1037 5 ^{7/16}	1037 8	L		15 – 17 ^{1/2}	RO1306 9	RX1207 ①	RO635 ①	R	
						12 ^{1/2} – 15	RO1306 9	RX1207 ①	RX1207 ①	S	
						10 – 12 ^{1/2}	RO1306 9	RO1036 ①	RX1207 ①	S	
					7 ^{1/2} – 10	X1307 10	RO1036 ①	RO1306 ①	U		
					5 – 7 ^{1/2}	X1307 9 ^{1/2}	RO1036 ①	RO1306 ①	W		
					4 – 5	①	X1307 ①	RO1306 ①	X		
					3 – 4	①	①	X1307 ①	Z		
60 DHP											
300 – 350	R1035 3 ^{15/16}	R514 4 ^{7/16} 3160 3 ^{3/16}	R3112 4 ^{15/16} 3140 3 ^{15/16}	G		70 – 80	RX238 4 ^{7/16}	RX238 7	R1037 8	M	
250 – 300	R1037 3 ^{11/16}	R514 4 ^{7/16} 3180 3 ^{11/16}	R3112 4 ^{15/16} 3160 4 ^{7/16}	H		60 – 70	R1248 4 ^{7/16}	RX238 7	AX1568 8 ^{1/2}	N	
200 – 250	R1037 3 ^{7/16}	R1033 5 ^{15/16} 3180 3 ^{11/16}	1030 6 ^{1/2} 3160 4 ^{7/16}	I		50 – 60	RX1245 5 ^{7/16}	RX238 7	RX238 9 ^{1/2}	O	
175 – 200	R1037 3 ^{7/16}	R1033 5 ^{15/16} 3180 3 ^{11/16}	1030 6 ^{1/2} 3160 4 ^{7/16}	I		45 – 50	RO635 5 ^{7/16}	R1248 8	RX238 9 ^{1/2}	O	
150 – 175	R1037 3 ^{15/16}	R1033 5 ^{15/16} 3180 3 ^{11/16}	1033 7 3180 4 ^{15/16}	J		40 – 45	RO635 5 ^{7/16}	R1248 8	RX238 9 ^{1/2}	O	
125 – 150	AX1568 3 ^{11/16}	R1037 5 ^{7/16}	R1033 7 3180 4 ^{15/16}	J		35 – 40	RO635 5 ^{7/16}	RX1245 8	R1248 10	P	
100 – 125	RX238 4 ^{7/16}	R1037 5 ^{7/16}	1037 7 ^{1/2} 3180 4 ^{15/16}	K		30 – 35	RO635 5 ^{7/16}	RO635 9 ^{1/2}	R1248 10	P	
90 – 100	RX238 4 ^{7/16}	R1037 5 ^{7/16}	1037 8	L		25 – 30	RX1207 6 ^{1/2}	RO635 9 ^{1/2}	RO635 ①	Q	
80 – 90	RX238 4 ^{7/16}	AX1568 5 ^{7/16}	1037 8	L		20 – 25	RX1207 6 ^{1/2}	RO635 9 ^{1/2}	RO635 ①	Q	
						17 ^{1/2} – 20	RO1306 9	RX1207 ①	RO635 ①	R	
						15 – 17 ^{1/2}	RO1306 9	RX1207 ①	RX1207 ①	S	
						12 ^{1/2} – 15	RO1306 9	RO1306 ①	RX1207 ①	S	
					10 – 12 ^{1/2}	RO1306 9	RO1306 ①	RX1207 ①	T		
					7 ^{1/2} – 10	X1307 10	RO1306 ①	RO1306 ①	U		

Note: 1. 3100 Series chain operates over roller chain cut tooth sprockets.

2. Fabricated steel sprockets are recommended.





① Consult Rexnord

② Hub size letter – See page 79.

DESIGN AND SELECTION

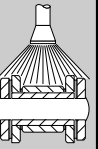
TABLE 2 (Cont'd.)
DRIVE CHAIN SELECTION TABLES

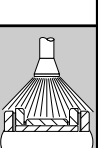
Note: Rex® drive chain selections are displayed in the tables. To interchange Link-Belt® and Rex chain numbers see pages 34-35.

Table 2 – (Cont'd.)											
RPM Driver Sprocket	DESIGN HORSEPOWER (DHP) = HP x SF For (SF) see pages 108-109				Type of Lubrication	RPM Driver Sprocket	DESIGN HORSEPOWER (DHP) = HP x SF For (SF) see pages 108-109				Type of Lubrication
	DRIVER SPROCKET – NO. OF TEETH LARGEST KEYSEATED BORE						DRIVER SPROCKET – NO. OF TEETH LARGEST KEYSEATED BORE				
	9T	12T	15T	Hub Letter [Ⓜ]			9T	12T	15T	Hub Letter [Ⓜ]	
70 DHP											
300 – 350		R514 4 ⁷ / ₁₆ 3180 3 ¹¹ / ₁₆	R514 5 ¹⁵ / ₁₆ 3160 4 ⁷ / ₁₆	H	 Oil Bath	60 – 70	RX1245 5 ⁷ / ₁₆	RX238 7	RX238 9 ¹ / ₂	O	Oil Bath
250 – 300	R1037 3 ⁷ / ₁₆	1030 5 ¹⁵ / ₁₆ 3180 3 ¹¹ / ₁₆	R514 5 ¹⁵ / ₁₆ 3160 4 ⁷ / ₁₆	I		50 – 60	RO635 5 ⁷ / ₁₆	R1248 8	RX238 9 ¹ / ₂	O	
200 – 250	R1037 3 ⁷ / ₁₆	R1033 5 ¹⁵ / ₁₆ 3180 3 ¹¹ / ₁₆	R1033 6 ¹ / ₂ 3160 4 ⁷ / ₁₆	I		45 – 50	RO635 5 ⁷ / ₁₆	R1248 8	RX238 9 ¹ / ₂	O	 Flow
175 – 200	R1037 3 ¹⁵ / ₁₆	R1033 5 ¹⁵ / ₁₆ 3180 3 ¹¹ / ₁₆	R1033 7 3180 4 ¹⁵ / ₁₆	J		40 – 45	RO635 5 ⁷ / ₁₆	RX1245 8	R1248 10	P	
150 – 175	AX1568 3 ¹¹ / ₁₆	R1037 5 ⁷ / ₁₆	R1033 7 3180 4 ¹⁵ / ₁₆	J		35 – 40	RX1207 6 ¹ / ₂	RO635 9 ¹ / ₂	R1248 10	P	
125 – 150	RX238 4 ⁷ / ₁₆	R1037 5 ⁷ / ₁₆	R1033 7 3180 4 ¹⁵ / ₁₆	J		30 – 35	RX1207 6 ¹ / ₂	RO635 9 ¹ / ₂	RO635 ⊕	Q	
100 – 125	RX238 4 ⁷ / ₁₆	R1037 5 ⁷ / ₁₆	R1033 7 3180 4 ¹⁵ / ₁₆	J		25 – 30	RX1207 6 ¹ / ₂	RO635 9 ¹ / ₂	RO635 ⊕	Q	
90 – 100	RX238 4 ⁷ / ₁₆	AX1568 5 ⁷ / ₁₆	R1037 8	M		20 – 25	RO1306 9	RX1207 ⊕	RO635 ⊕	R	
80 – 90	R1248 4 ⁷ / ₁₆	RX238 7	R1027 8	M		17 ¹ / ₂ – 20	RO1306 9	RX1207 ⊕	RX1027 ⊕	S	
70 – 80	R1248 4 ⁷ / ₁₆	RX238 7	AX1568 8 ¹ / ₂	N		15 – 17 ¹ / ₂	RO1306 9	RO1306 ⊕	RX1027 ⊕	S	
						12 ¹ / ₂ – 15	RO1306 9	RO1306 ⊕	RX1027 ⊕	T	
						10 – 12 ¹ / ₂	X1307 10	RO1306 ⊕	RO1306 ⊕	U	
						7 ¹ / ₂ – 10	⊕	RO1306 ⊕	RO1306 ⊕	V	
						5 – 7 ¹ / ₂	⊕	X1307 ⊕	X1307 ⊕	Y	
										Manual	
80 DHP											
300 – 350		R1035 5 ⁷ / ₁₆ 3180 3 ¹¹ / ₁₆	R514 5 ¹⁵ / ₁₆ 3160 4 ⁷ / ₁₆	H	 Oil Bath	50 – 60	RO635 5 ⁷ / ₁₆	R1248 8	RX238 9 ¹ / ₂	O	Oil Bath
250 – 300	AX1568 2 ¹⁵ / ₁₆	R1035 5 ⁷ / ₁₆ 3180 3 ¹¹ / ₁₆	R514 5 ¹⁵ / ₁₆ 3180 4 ¹⁵ / ₁₆	I		45 – 50	RO635 5 ⁷ / ₁₆	RO635 9 ¹ / ₂	R1248 10	P	
200 – 250	AX1568 3 ¹¹ / ₁₆	R1035 5 ⁷ / ₁₆ 3180 3 ¹¹ / ₁₆	R1033 7 3180 4 ¹⁵ / ₁₆	J		40 – 45	RX1207 6 ¹ / ₂	RO635 9 ¹ / ₂	R1248 10	P	 Flow
175 – 200	AX1568 3 ¹¹ / ₁₆	R1037 5 ⁷ / ₁₆	R1033 7 3180 4 ¹⁵ / ₁₆	J		35 – 40	RX1207 6 ¹ / ₂	RO635 9 ¹ / ₂	RO635 ⊕	Q	
150 – 175	RX238 4 ⁷ / ₁₆	R1037 5 ⁷ / ₁₆	R1035 7 ¹ / ₂ 3180 4 ¹⁵ / ₁₆	K		30 – 35	RX1207 6 ¹ / ₂	RO635 9 ¹ / ₂	RO635 ⊕	Q	
125 – 150	RX238 4 ⁷ / ₁₆	R1037 5 ⁷ / ₁₆	R1035 7 ¹ / ₂ 3180 4 ¹⁵ / ₁₆	K		25 – 30	RO1306 9	RX1207 ⊕	RO635 ⊕	R	
100 – 125	RX238 4 ⁷ / ₁₆	AX1568 5 ⁷ / ₁₆	R1037 8	M		20 – 25	RO1306 9	RX1207 ⊕	RX1207 ⊕	S	
90 – 100	R1248 4 ⁷ / ₁₆	RX238 7	AX1568 8 ¹ / ₂	M		17 ¹ / ₂ – 20	RO1306 9	RO1306 ⊕	RX1207 ⊕	S	
80 – 90	RX1245 4 ⁷ / ₁₆	RX238 7	AX1568 8 ¹ / ₂	N		15 – 17 ¹ / ₂	RO1306 9	RO1306 ⊕	RX1207 ⊕	T	
70 – 80	RO635 5 ⁷ / ₁₆	RX238 7	RX238 9 ¹ / ₂	O		12 ¹ / ₂ – 15	RO1306 8 ¹ / ₂	RO1306 ⊕	RO1306 ⊕	U	
60 – 70	RO635 5 ⁷ / ₁₆	R1248 8	RX238 9 ¹ / ₂	O		10 – 12 ¹ / ₂	⊕	RO1036 ⊕	RO1306 ⊕	U	
						7 ¹ / ₂ – 10	⊕	X1307 ⊕	RO1306 ⊕	W	
						5 – 7 ¹ / ₂	⊕	⊕	X1307 ⊕	Y	
											Manual
90 DHP											
300 – 350		R1035 5 ⁷ / ₁₆ 3180 3 ¹¹ / ₁₆	R514 5 ¹⁵ / ₁₆ 3160 4 ⁷ / ₁₆	I	 Oil Bath	60 – 70	RO635 5 ⁷ / ₁₆	R1248 8	RX238 9 ¹ / ₂	O	Oil Bath
250 – 300	AX1568 2 ¹⁵ / ₁₆	R1035 5 ⁷ / ₁₆ 3180 3 ¹¹ / ₁₆	R514 5 ¹⁵ / ₁₆ 3180 4 ¹⁵ / ₁₆	I		50 – 60	RO635 5 ⁷ / ₁₆	RO635 9 ¹ / ₂	R1248 10	P	
200 – 250	AX1568 3 ¹¹ / ₁₆	R1037 5 ⁷ / ₁₆	R514 5 ¹⁵ / ₁₆ 3180 4 ¹⁵ / ₁₆	J		45 – 50	RX1207 6 ¹ / ₂	RO635 9 ¹ / ₂	R1248 10	P	 Flow
175 – 200	RX238 4 ⁷ / ₁₆	R1037 5 ⁷ / ₁₆	R1033 7 ¹ / ₂ 3180 4 ¹⁵ / ₁₆	K		40 – 45	RX1207 6 ¹ / ₂	RO635 9 ¹ / ₂	RO635 ⊕	Q	
150 – 175	RX238 4 ⁷ / ₁₆	R1037 5 ⁷ / ₁₆	R1037 7 ¹ / ₂	K		35 – 40	RX1207 6 ¹ / ₂	RO635 9 ¹ / ₂	RO635 ⊕	Q	
125 – 150	RX238 3 ¹¹ / ₁₆	AX1568 5 ⁷ / ₁₆	R1037 8	L		30 – 35	RX1207 6 ¹ / ₂	RO635 9 ¹ / ₂	RO635 ⊕	Q	
100 – 125	R1248 4 ⁷ / ₁₆	RX238 7	AX1568 8 ¹ / ₂	M		25 – 30	RX1207 6 ¹ / ₂	RX1207 ⊕	RO635 ⊕	R	
90 – 100	RX1245 4 ⁷ / ₁₆	RX238 7	AX1568 8 ¹ / ₂	N		20 – 25	RO1306 9	RO1306 ⊕	RX1207 ⊕	S	
80 – 90	RO635 5 ⁷ / ₁₆	RX238 7	RX238 9 ¹ / ₂	O		17 ¹ / ₂ – 20	RO1306 9	RO1306 ⊕	RX1207 ⊕	S	
70 – 80	RO635 5 ⁷ / ₁₆	R1248 8	RX238 9 ¹ / ₂	O		15 – 17 ¹ / ₂	X1307 10	RO1306 ⊕	RO1306 ⊕	T	
						12 ¹ / ₂ – 15	⊕	RO1306 ⊕	RO1306 ⊕	U	
						10 – 12 ¹ / ₂	⊕	RO1306 ⊕	RO1306 ⊕	V	





Note: 1. 3100 Series chain operates over roller chain cut tooth sprockets.
2. Fabricated steel sprockets are recommended.

Ⓜ Consult Rexnord
Ⓜ Hub size letter – See page 79.

DESIGN AND SELECTION

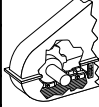
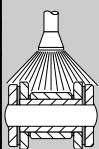
TABLE 2 (Cont'd.)
DRIVE CHAIN SELECTION TABLES

Note: Rex® drive chain selections are displayed in the tables. To interchange Link-Belt® and Rex chain numbers see pages 34-35.

Table 2 – (Cont'd.)													
RPM Driver Sprocket	DESIGN HORSEPOWER (DHP) = HP x SF For (SF) see pages 108-109				Type of Lubrication	RPM Driver Sprocket	DESIGN HORSEPOWER (DHP) = HP x SF For (SF) see pages 108-109				Type of Lubrication		
	DRIVER SPROCKET – NO. OF TEETH LARGEST KEYSEATED BORE						DRIVER SPROCKET – NO. OF TEETH LARGEST KEYSEATED BORE						
	9T	12T	15T	Hub Letter ²			9T	12T	15T	Hub Letter ²			
100 DHP													
300 – 350		3180 3 ^{11/16}	R514 5 ^{15/16} 3180 4 ^{15/16}	I		50 – 60	RX1207 6 ^{1/2}	RO635 9 ^{1/2}	R1248 10	P			
250 – 300		R1037 5 ^{7/16}	R1035 7 3180 4 ^{15/16}	J		45 – 50	RX1207 6 ^{1/2}	RO635 9 ^{1/2}	RX1245 10	P			
200 – 250		R1037 5 ^{7/16}	R1035 7 ^{1/2} 3180 4 ^{15/16}	K		40 – 45	RX1207 6 ^{1/2}	RO635 9 ^{1/2}	RO635 ①	Q		Oil Bath	
175 – 200		R1037 5 ^{7/16}	R1037 7 ^{1/2}	K		35 – 40	R1035 9	RO635 9 ^{1/2}	RO635 ①	R			
150 – 175	RX238 4 ^{7/16}	R1037 5 ^{7/16}	R1037 8	L		30 – 35	RO1306 9	RX1207 ①	RO635 ①	R			
125 – 150	R1248 4 ^{7/16}	RX238 7	R1037 8	M		25 – 30	RO1306 9	RX1207 ①	RX1207 ①	S			
100 – 125	RX1245 4 ^{7/16}	RX238 7	AX1568 8 ^{1/2}	N		20 – 25	RO1306 9	RO1306 ①	RX1207 ①	S			
90 – 100	RO635 5 ^{7/16}	RX238 7	RX238 9	N		17 ^{1/2} – 20	RO1306 9	RO1306 ①	RX1207 ①	T			
80 – 90	RO635 5 ^{7/16}	R1248 8	RX238 9 ^{1/2}	O		15 – 17 ^{1/2}	①	RO1036 ①	RO1036 ①	U			
70 – 80	RO635 5 ^{7/16}	R1248 8	R238 9 ^{1/2}	O		12 ^{1/2} – 15	①	RO1036 ①	RO1036 ①	U			
60 – 70	RX1245 5 ^{7/16}	RX1245 8	R1248 10	P	10 – 12 ^{1/2}	①	X1307 ①	RO1036 ①	W				
					7 ^{1/2} – 10	①	①	X1307 ①	X				
125 DHP													
200 – 250		AX1568 5 ^{7/16}		L		45 – 50		RO635 9 ^{1/2}	RO635 ①	Q			
175 – 200		AX1568 5 ^{7/16}	R1037 8	L		40 – 45		RX1207 ①	RO635 ①	R			
150 – 175		RX238 7	R1037 8	M		35 – 40		RX1207 ①	RO635 ①	R			
125 – 150		RX238 7	AX1568 7 ^{1/2}	N		30 – 35		RX1207 ①	RX1207 ①	S			
100 – 125		R1248 8	RX238 9 ^{1/2}	O		25 – 30		RO1306 ①	RX1207 ①	S			
90 – 100		R1248 8	RX238 9 ^{1/2}	O		20 – 25		RO1306 ①	RO1306 ①	T			
80 – 90		R1248 8	RX238 9 ^{1/2}	O		17 ^{1/2} – 20		RO1306 ①	RO1306 ①	U			
70 – 80		RO635 9 ^{1/2}	R1248 10	P		15 – 17 ^{1/2}		RO1306 ①	RO1306 ①	V			
60 – 70		RO635 9 ^{1/2}	R1248 10	P		12 ^{1/2} – 15		①	RO1306 ①	W			
50 – 60		RO635 9 ^{1/2}	RO635 ①	Q					RO1306 ①	X			
150 DHP													
175 – 200			R1037 8	M		45 – 50			RO635 ①	R			
150 – 175			AX1568 7 ^{1/2}	N		40 – 45			RX1207 ①	R			
125 – 150			RX238 9 ^{1/2}	O		35 – 40			RX1207 ①	S			
100 – 100			RX238 9 ^{1/2}	O		30 – 35			RX1207 ①	S			
90 – 100			R1248 10	P		25 – 30		RO1306 ①	RO1306 ①	T			
80 – 90			R1248 10	P		20 – 25		RO1306 ①	RO1306 ①	U			
70 – 80			RX1245 10	P		17 ^{1/2} – 20		①	RO1306 ①	V			
60 – 70			RO635 ①	Q		15 – 17 ^{1/2}		①	RO1306 ①	W			
50 – 60			RO635 ①	Q		12 ^{1/2} – 15		①	RO1306 ①	X			

Note: 1. 3100 Series chain operates over roller chain cut tooth sprockets.
2. Fabricated steel sprockets are recommended.

① Consult Rexnord

② Hub size letter – See page 79.

■ DESIGN AND SELECTION

CONVEYOR CHAIN SELECTION PROCEDURES

Conveyor Classes

A second consideration closely related to the type of conveyor is the conveyor class. Six conveyor classes have been established on the basis of friction factors involved with the movement of the chain (sliding or rolling) and the movement of the material (sliding or carried). These six classes are described in terms of chain and material movement in the following table:

Conveyor Classes		
Class	Chain	Material
1	Sliding, with flights	Sliding
1A	Sliding, without flights	Sliding
2	Rolling	Sliding
3	Sliding	Carried
4	Rolling	Carried
4A	Supplemental Roller	Carried

Basic Conveyor Arrangements

There are several basic conveyor arrangements. The recommended arrangement (see illustration) is with the drive at the head end and with the carrying and return runs well supported. Note the catenary sag in the return run at the head end. In general, the catenary sag should be at least equal to 3% of the span over which the chain is hanging. The illustrated arrangement offers two advantages:

- The catenary force tends to keep the chain engaged on the drive sprocket.
- Wear at the chain joints is minimal because the return run is under minimum tension and flexure at the chain joints is reduced by the well-supported return line.

If a take-up is used to adjust the center distance and maintain the correct catenary sag, be extremely cautious not to impose excessive loads on the chain.

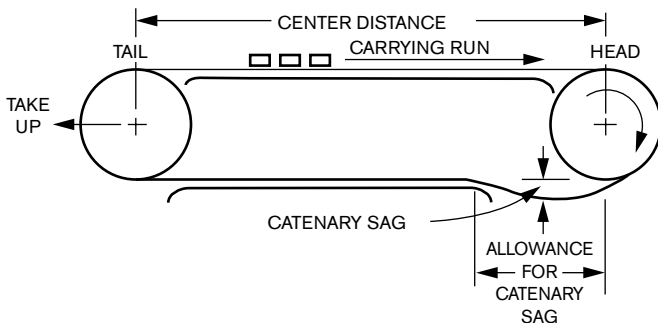

Other Arrangements

Other methods of supporting the return run are shown in the following illustrations.

These methods of support will result in faster chain wear because of the additional flexure at the joints in the return line and the higher pressure between the chain and the return support because of the small area of support.

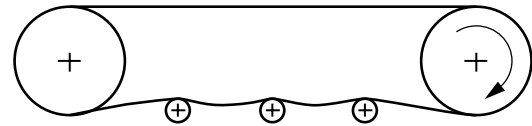

Return Strand Supported by Rollers

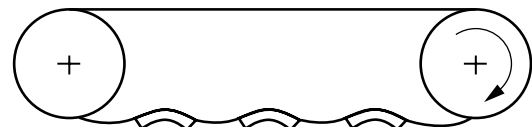

Return Strand Supported by Shoes

Conveyors sometimes are driven from the tail end as shown in the following illustration.

This arrangement is not recommended for two main reasons:

- Chain wear at the joints is greater because chain is flexing under load at both the head and tail sprockets.
- Excess chain tends to accumulate on the carrying run just after the tail sprocket and the resulting wedging action can cause the chain to jump the sprocket.

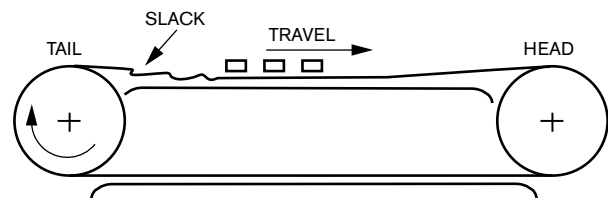

DESIGN AND SELECTION

Method of Chain Travel

Another basic consideration is whether the chain will slide or roll. In deciding on the method of chain travel, the following points should be evaluated:

Chain Sliding

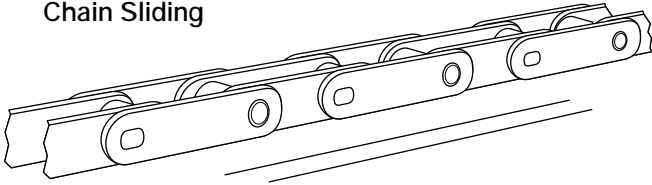

- Simple in construction, fewer moving parts and usually the lowest in cost for a given load.
- Most effective in “dirty” applications.
- Greater horsepower required.

Chain Rolling

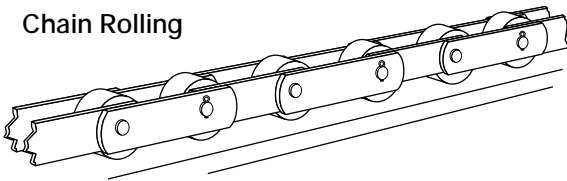

- Smoother operation, less pulsation.
- Lower friction which permits longer centers, smaller motors, and lower operating costs.
- Not suited to “dirty” applications, foreign matter jams rollers.
- Less horsepower required.

Conveyor Pulsation

Another consideration is the amount of pulsation that can be tolerated in the conveyor. This will vary from one installation to another and the permissible amount is a matter of judgement. When pulsation must be minimized, consider the possible causes and remedies listed in the following table:

Possible Cause	Remedy
Excessive friction	Clean and lubricate moving parts.
Conveyor too long	Use shorter conveyor sections.
Conveyor speed too low (10 fpm or less)	Increase conveyor speed, or use non-metallic-bushed chain.
Velocity fluctuation caused by chordal action	Use drive sprocket with 12 or more teeth, or – Use compensating sprocket. (Consult your Rexnord representative.)

Carrying Loads of Rollers

A basic consideration on conveyors using chain with rollers is the load imposed on the chain. This load includes the weight of the slats or flights, and the weight of the material being carried. This load must be limited so that the pressure of the bushing on the roller is kept within permissible limits.

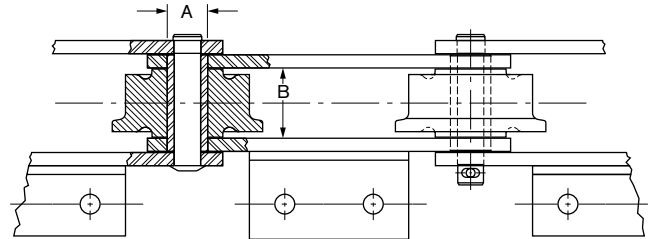

A = Roller-bore diameter } Applies also to
B = Roller hub length } outboard rollers.

Roller-bearing area = $A \times B$

The roller carrying pressure, per roller, is distributed over the roller-bearing area.

The table below lists allowable bearing pressures between bushings and roller. Note the method of determining the roller bearing area. The listed bearing pressures are for “ideal conditions”, i.e. slow speeds in non-gritty service with lubricated bearings. As any of these conditions become more severe, the allowable pressures must be reduced accordingly.

The allowable working bearing pressures, in pounds per square inch between rollers and bushings, are approximately as follows:

Roller and Bushing Materials in Contact	Allowable Bearing Pressure P.S.I.
Casehardened steel against casehardened steel	1400
Casehardened steel against white iron	1400
Casehardened steel against untreated steel	1200
Casehardened steel against cast iron	1000 ^⓪
Casehardened steel against malleable iron	1000
Casehardened steel against bronze	400
Gray iron against malleable iron	800
Malleable iron against malleable iron	800
Gray iron against bronze	800
Non-metallic against carburized steel or heat treated stainless steel (LF bushed rollers)	100

^⓪ Applies also to chill iron.

■ DESIGN AND SELECTION

CONVEYOR CHAIN SELECTION PROCEDURES – (Cont'd.)

Wear Strips and Ways

Generally, it is desirable that the chain wear slower than the wear strips or liner since it is the more critical and expensive part of the conveyor components. Therefore, the most compatible wear strip should be considered after the proper chain has been selected. Conveyor may wear for chains rolling is not a critical consideration but cold finished steel is used for best operation.

The subject of wear is extremely complicated and influenced by many factors. It is impossible to predict with accuracy the wear life of various chain – liner combinations. This is due to the effect of many variable and uncontrollable factors such as abrasion, corrosion, lubrication, load, speed, and break-in period. Thus, prior experience of a successful chain – liner combination for a specific application is the best guide to predict performance.

For new installations, where no previous experience can be applied as a guide, the chain should be slightly harder than a metal liner to protect it and insure that the liner wears first. The material should be at least comparable to the chain in surface finish or smoother.

Non-metallic materials such as, wood and plastic, are occasionally used as liner materials. These may result in wear strip economy, but should not be used where severe impacting loads exist or under extremely dirty conditions.

If wear is a problem, neglecting the effect of corrosion, experience has shown that generally by increasing the hardness of either the chain or the metallic wear strip in an abrasive environment should decrease the wear on both. Lubrication, even if only water will reduce wear.

Some general comments to insure proper installation of liners in the conveyor and things to do before start-up are:

1. See that the joints on the liners and frame are smooth so that no sharp edges protrude.
2. Take reasonable care in eliminating welding slag, weld spatter, metal filings and/or mill scale from the conveyor.
3. Break in chain and liner by operating the conveyor without load, and with plenty of lubricant, for a short period of time (generally 8-24 hours) or until the mating wear surfaces are polished smooth.

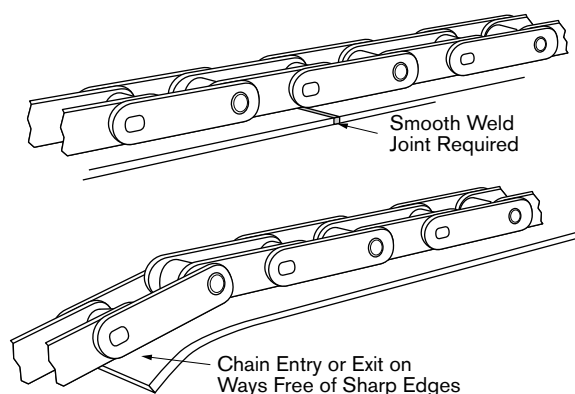

Note: The above comments are guidelines that normally will increase or improve chain – liner compatibility.

ABRASION RESISTANT STEEL ALLOYS THAT MAY BE USED AS LINER MATERIAL ^①					
Name	Producer Code ^② Condition		Mechanical Properties		
			Hardness BHN	Yield 1000 PSI	Tensile 1000 PSI
SSS-321	ARM	Q & T	321	–	–
SSS-360	ARM	Q & T	360	–	–
SSS-400	ARM	Q & T	400	–	–
Sheffield AR	ARM	HR	225	–	–
AR-No. 235	B	HR	(235)	70	100
Abrasion Resisting, Med. Hard.	IN	HR	235	–	–
Abrasion Resisting, Full Hard.	IN	HR	270	–	–
Jalloy AR-280	JL	Q & T	260	110	117
Jalloy AR-320	JL	Q & T	300	135	142
Jalloy AR-360	JL	Q & T	340	160	166
Jalloy AR-400	JL	Q & T	400	184	190
Jalloy S-340	JL	Q & T	320	149	157
Jalloy 3 (AR)	JL	HR	(225)	90	104
T-1-A-360	L	Q & T	360	(145)	(180)
XAR-15	N	Q & T	360	165	180
XAR-30	N	Q & T	360	165	180
USS-AR	US	HR	(235)	–	100
T-1	US/L	Q & T	321	(100)	(115)
T-1-A	US/L	Q & T	321	(100)	(115)
T-1-A-321	US/L	Q & T	321	(137)	(171)
T-1-B-321	US/L	Q & T	321	(137)	(171)
T-1-321	US/L	Q & T	321	(141)	(175)
T-1-360	US/L	Q & T	360	(145)	(180)
Astralloy	V	N	440	(141)	(228)

^① Presented as a guide only. If additional information is required, contact the designated steel company.

^② Producer Code: ARM = Armco Steel Corp.; B = Bethlehem Steel Corp.; IN = Inland Steel Co.; JL = Jones & Laughlin Steel Corp.; L = Lukens Steel Co.; N = National Steel Corp.; US = United States Steel Corp.; V = Vulcan Steel Corp.

Note: Q & T = quenched and tempered; HR = hot rolled; N = normalized. Typical values are enclosed in parentheses.

Mechanical properties are those of sheet or hot rolled plate up to 1/2" thick and are minimums unless typical is indicated by parentheses.

DESIGN AND SELECTION

This procedure is intended to serve primarily as a guide for selecting a general type, or class, of chain when a new conveyor is designed. When following the step-by-step instruction outlined, the user may find that more than one type of chain will fit the particular conveyor requirement. In such a case the final selection of the chain may be affected by such factors as allowable sprocket diameters, space limitations for chain, chain pitch, and many other environmental and design factors peculiar to the particular conveyor being designed. Consult your Rexnord representative for assistance in selecting the best chain when a choice of more than one class is indicated.

Parts of this section will prove useful in determining whether the chain on existing installations is the most economical choice, and will also serve as a guide to upgrading existing installations where service life is not satisfactory.

Procedure

There are six basic steps in selecting the proper type of chain for a conveyor installation.

1. Determine the class of conveyor.
2. Estimate the total chain pull.
3. Determine the design working load.
4. Make a tentative chain selection.
5. Make tentative selection of attachment links.
6. Verify chain selection and re-check design working load.

Step 1. Determine the Class of Conveyor

Check the sections on Conveyor Types, Conveyor Classes, and Method of Chain Travel in relation to your conveying problem.

Make a tentative selection of a conveyor class required from the table on page 119.

Step 2. Estimate the Total Chain Pull (P_m).

Use the formula which applies to the conveyor class tentatively selected and calculate total chain pull (P_m) which is total conveyor chain pull.

For conveyors that are partly horizontal and partly inclined, calculate the chain pull for each section, and add to obtain total chain pull.

Note: Calculations assume properly adjusted take-up equipment. If take-up force is adjusted to exceed the calculated value (P₂ + P₃), excessive chain loading may result.

Class 1, 1A and 2 Conveyors

(Chain sliding or rolling; Material sliding)

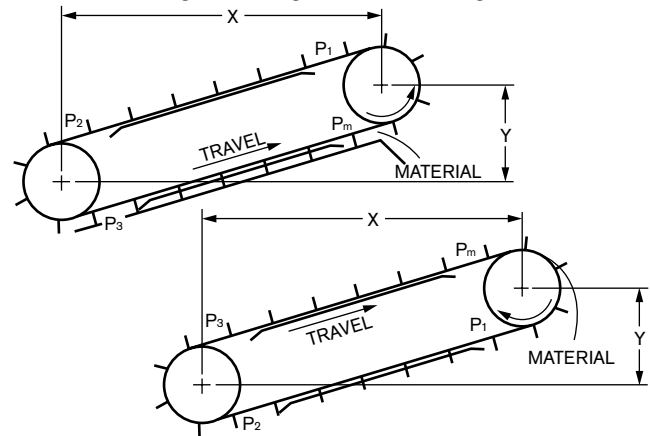

Formulas for Calculating Total Chain Pull (P_m)

Horizontal: ($\frac{Y}{X}$ is less than f_1)

$$P_m = X (2f_1W + f_2M + \frac{h^2}{c}) + MY$$

Inclined: ($\frac{Y}{X}$ is greater than f_1)

$$P_m = X (f_1W + f_2M + \frac{h^2}{c}) + Y (W + M)$$

Class 3, 4 and 4A Conveyors

(Chain sliding, rolling or in tension; Material carried)

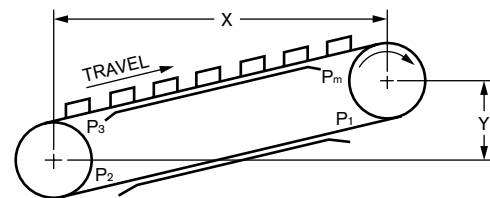

Formulas for Calculating Total Chain Pull (P_m)

Horizontal: ($\frac{Y}{X}$ is less than f_1)

$$P_m = f_1X (2W + M) + MY + \frac{h^2}{c}X$$

Inclined: ($\frac{Y}{X}$ is greater than f_1)

$$P_m = (M + W) (f_1X + Y) + \frac{h^2}{c}X$$

Formulas for Calculating Horsepower (HP)

Horizontal:

$$HP = \frac{1.15 (S) (P_m)}{33,000}$$

Inclined:

$$HP = \frac{1.15 (S) (P_m - P_1)}{33,000}$$

$$P_1 = W (Y - f_1X)$$

$$P_2 = P_3 = 0$$

Note: Symbol identification given on page 152.

■ DESIGN AND SELECTION

CONVEYOR CHAIN SELECTION PROCEDURES – (Cont'd.)

Symbols

f₁ = Coefficient of Friction – chain sliding or rolling on runway. See next column for specific value of the coefficient.

If chain is supported by flights, etc., **f₁** should be coefficient for flights sliding on conveyor ways.

f₂ = Coefficient of Friction – material sliding on trough. (See Table in next column).

M = Wt. of material handled per foot of conveyor (lb./ft.)

$$M = \frac{(TPH)(33.3)}{S}$$

$$M = \frac{(CFH) (\text{Mat'l. Density in LB/FT}^3)}{60(S)}$$

W = Weight of moving conveyor parts – chains, flights, slats, etc., per foot of chain (lbs/ft). Depending on the method of chain travel, use the following factors for estimating approximate chain weight (lbs/ft) if actual chain weight is unknown.

Material or chain sliding – .0015 x Total weight of material on conveyor at any time (lbs.). (Classes 1, 1A, 2 or 3)

Material carried and Chain rolling – .0005 x Total weight of material on conveyor at any time (lbs.). (Classes 4 and 4A)

For example: If a Class 4 Conveyor is used and the total material weight is 40,000 pounds, then 40,000 x .0005 = 20.0

Use 20.0 Lbs/Ft. as an estimated chain weight for “W” in the above equation. Add the estimated Weight/Ft. on the flights or slats that will be used.

h = Height of material rubbing against side of conveyor trough (inches).

c = Trough side friction constant (see Table in next column).

P_m = Total Maximum Chain pull (lbs)

P₁ }
P₂ } Chain pull at point indicated (lbs)
P₃ }

HP = Required horsepower at headshaft

S = Conveyor Speed (ft/min)

TPH = Capacity in Tons per Hour = $\frac{MS}{33.3}$

CFH = Capacity in cubic feet per hour
 = $\frac{TPH \times 2000}{(\text{Mat'l. Density in lb/ft}^3)}$

X = Horizontal center distance (ft.)

Y = Vertical rise (ft.)

Chain Friction Factors (f₁)

Chain Sliding

Chain Sliding on Steel Track – unlubricated3-.5

Chain Sliding on Steel Track – lubricated2

Chain Sliding on Hard Wood5

Chain Sliding on Non-Metallic Wear Strips:

Chain Sliding on Ultra-High Molecular

Weight Polyethylene15-.4

Chain Rolling

$$f_1 = f_r \frac{d_a}{d_r}$$

Where: **d_a** = axle diameter (inches) (usually bushing O.D.)

d_r = roller outside diameter (inches)

(f _r) For Metal Rollers			
Cast Rollers		Steel Rollers	
Dry	.5	Dry	.4
Lubricated	.4	Lubricated	.3

For LF (Low Friction material) Bushed Rollers, **f_r** = .25

Material Friction Factors

Materials	Friction Factor Mat'l Sliding on Steel Trough (f ₂)	Trough Side Friction Fadtcor (c)
Aluminum	.40	27
Ashes, Coal, Dry	.50	36
Ashed, Coal, Wet	.60	55
Bagasse	.40	200
Cement, Portland	.65	12
Cement Clinker	.70	12
Coal, Anthracite, Sized	.40	25
Coal, Anthracite, Run of Mine	.45	20
Coal, Bituminous, Sized	.50	21
Coal, Bituminous, Run of Mine	.55	20
Coke, Mixed	.55	42
Coke, Breeze	.65	36
Grains	.40	23
Gravel, Dry	.45	12
Gravel, Run of Bank	.60	11
Ice, Crushed	.15	34
Lime, Pebble	.50	28
Sand, Dry	.60	7
Sand, Damp	.85	6
Stone, Screened	.60	9
Wood Chips, Pulp Logs	.40	48

DESIGN AND SELECTION

Step 3. Determine the Design Working Load

The determination of chain pull (P_m) is for static conditions and does not include consideration of the following dynamic conditions:

- Loading fluctuations that may exceed the static load condition. These fluctuations are provided for by the Service Factor. (See table below.)
- The conveyor chain speed and the number of teeth in the sprockets used. These items are provided for by the Speed Factor (F_s). (See table below.)

Calculate the Design Working load by modifying P_m as follows:

For single strand conveyor:

$$\text{Design Working Load} = P_m \times \text{Service Factor} \times \text{Speed Factor}$$

For multiple strand conveyor:

$$\text{Design Working Load} = P_m \times \text{Service Factor} \times \text{Speed Factor} \times \frac{1.2}{\text{No. of Strands}}$$

The multiplier (1.2) is used to provide for possible overloads in one of the strands caused by unequal load sharing distribution.

Speed Factors (F_s)

No. of Teeth on Sprocket	50		100		150		200		300		400	
	Cast Chain	Engineered and Welded Steel Chain	Cast Chain	Engineered and Welded Steel Chain	Cast Chain	Engineered and Welded Steel Chain	Cast Chain	Engineered and Welded Steel Chain	Cast Chain	Engineered and Welded Steel Chain	Cast Chain	Engineered and Welded Steel Chain
6	1.6	1.4	2.3	2.0	2.3	2.9	5.0	4.4	–	–	–	–
7	1.3	1.1	1.6	1.4	2.0	1.8	2.6	2.3	4.5	4.0	–	–
8	1.2	1.0	1.4	1.3	1.7	1.5	2.0	1.8	2.9	2.5	4.2	3.6
9	1.1	1.0	1.3	1.2	1.6	1.4	1.8	1.6	2.3	2.0	2.9	2.6
10	1.0	0.9	1.3	1.1	1.4	1.2	1.6	1.4	1.9	1.7	2.3	2.0
11	1.0	0.9	1.2	1.0	1.3	1.2	1.5	1.3	1.7	1.5	2.1	1.8
12	1.0	0.9	1.1	1.0	1.3	1.1	1.4	1.2	1.6	1.4	1.9	1.6
14	1.0	0.8	1.1	0.9	1.2	1.0	1.3	1.1	1.5	1.3	1.7	1.4
16	0.9	0.8	1.0	0.9	1.1	1.0	1.2	1.0	1.4	1.2	1.5	1.3
18	0.9	0.8	1.0	0.9	1.0	0.9	1.2	1.0	1.3	1.1	1.5	1.3
20	0.9	0.8	1.0	0.9	1.0	0.9	1.1	1.0	1.3	1.1	1.5	1.2
24	0.9	0.8	0.9	0.8	1.0	0.9	1.1	0.9	1.2	1.0	1.3	1.2

Note: If sprocket size has not yet been determined, use a speed factor for a 12-tooth sprocket. Refer to sprocket selection beginning on page 75.

Determination of Speed Factor for Traction Wheels

- Determine effective pitch diameter (PD_{eff}): (PD_{eff}) = Traction wheel O.D. + barrel O.D. (chain)
- Compare (PD_{eff}) to pitch diameters of standard engineering sprockets. If (PD_{eff}) falls between two standard pitch diameters, go to the lower value.
- The standard pitch diameter chosen from No. 2 above will give number of teeth.
- Knowing number of teeth and chain speed, speed factor (F_s) can be determined.

Service Factor

Type of Load	Operating Conditions ^①		Daily Operated Period	
	Start Stop Frequency Under Load	% Load Added At a Time	8-10 Hrs.	24 Hrs.
Uniform	Less Than 5/Day	Less Than 5%	1.0	1.2
Moderate Peaks	5/Day to 2/Hr.	5-20%	1.2	1.4
High Peaks	2/Hr. to 10/Hr.	20% to 40%	1.5	1.8
Temperature	Operating Conditions		Service Factors	
	Up to 200°F (93°C)		1.0	
	200°F to 350°F (93°C to 177°C)		1.1	
	350°F to 500°F (177°C to 260°C)		1.2	
	Above 500°F (260°C)		Contact Rexnord	

The “Start-Stop” and “% loaded” parameters are intended to guide you in classifying the severity of loading for your conveyor. If these two parameters fall into different categories (ex. start-stop less than 5/Day, % loaded at a time 5-20%) use the more severe classification (moderate).

^① Reversing under load can be damaging and requires special consideration. Consult Rexnord for selection assistance.

■ DESIGN AND SELECTION

CONVEYOR CHAIN SELECTION PROCEDURES – (Cont'd.)

Step 4. Make Tentative Chain Selection

To aid in making the selection, consider the following:

- a. The wear life and relative cost of each type.
- b. Short conveyor centers and high chain speeds produce rapid joint wear and chain elongation. These conditions suggest a chain with a high (A or B) wear rating.
- c. Heavy loads produce rapid sliding and rolling wear. These conditions suggest a chain with a high (A or B) sliding or rolling wear rating.
- d. Conveyors operating in highly abrasive surroundings require hard bearing surfaces. This condition would suggest a steel chain.
- e. Mildly abrasive or moderately corrosive conditions may indicate that a cast chain is the economical choice.
- f. Corrosive atmospheres reduce the fatigue strength of component parts. In this case, chain with armor cased pins are recommended.
- g. The chain pitch may be dictated by the required spacing of attachment links. A longer pitch is more economical while a shorter pitch requires less room for sprockets. In many cases a 4" to 6" pitch chain is considered a good compromise.
- h. The selection procedure outlined is applicable only if temperatures of the chain will remain within -40°F and +350°F. Special lubricants may be needed above 250°F. If these temperature limits will be exceeded, consult your Rexnord representative.

Additional factors such as sprocket availability and price, chain delivery lead time and chain price should also be considered in making the final choice.

In making the final selection reliability should be a primary consideration. Cast chains, in general, do a good job in sliding applications and have excellent corrosion resistance. However, in critical applications where overloads may be encountered, Engineered Steel and Welded Steel chains will usually provide longer and more dependable service. It is recommended, therefore, that the final selection be made from the listings of Engineered Steel and Welded Steel Chains. Refer to the detail listings for the type of chain selected and select a specific chain that has a working load at least equal to the design working load and meets the pitch and space requirements.

REXNORD DOES NOT RECOMMEND CAST, CAST COMBINATION NOR WELDED STEEL CHAINS FOR ELEVATOR SERVICE.

Step 5. Make Tentative Selection of Attachment Links

Refer to the section on attachments. On the basis of the information here and on the basis of the chain selected, tentatively select the desired attachment links.

Step 6. Verify Chain Selection and Re-Check Design Working Load

Recalculate total chain pull (Pm) and design working load using the exact chain and attachment weight as given in the listings to verify that the selected chain will meet the requirements.

Selection Procedure for Double Flex Chains

This procedure is the same as that for standard chains except that the "Chain Pull" as determined must be modified. The modification is necessary because the chain is flexing around curves and additional tension is developed because of the friction between the **sides** of the chain and curves. The chain pull must be calculated on a **cumulative** basis, with the "Turn Factor" for each curve taken into account. Consult Rexnord for assistance in applying the proper "Turn Factor" for your conveyor.

DESIGN AND SELECTION

Conveyor Chain Selection

A horizontal scraper flight conveyor has been tentatively designed to handle Bituminous coals, and will feed an incinerator from a coal storage hopper. The coal is to be conveyed in an existing trough which is approximately 100 feet long and has a cross section as shown in the sketch below.

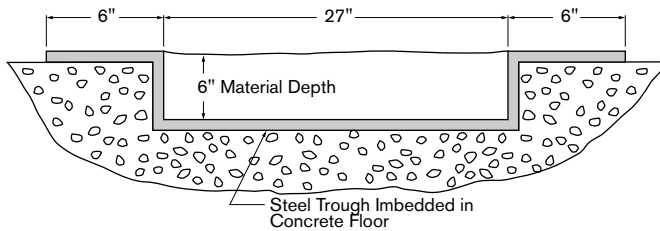

Conveyor Data

- Material Handled: *Bituminous Coal*
($1/2$ " maximum lump size)
- Material Density: *50 Lbs. per cubic foot*
- Conveyor Centers: *100 Feet*
- Conveyor Capacity: *170 Tons per hour*
- Conveyor Speed: *100 Feet per minute*

Other Considerations

1. Approximately 100 steel plates ($1/4$ " x 10" x 27"; Weight 10 Lbs.) are left over from another project, complete with attachment wings. It is desired to use these as flights if possible. Attachment wings are available to suit chain.
2. No space restrictions.
3. Conveyor to operate 16 hours per day. 5 days per week.
4. Drive will be selected to suit conveyor.

Select Suitable Chain

Step 1. Determine Conveyor Class

In the basic considerations section of this procedure, it was pointed out that a conveyor using a chain that rolled would result in smoother operation. Since a rolling chain also has less friction, smaller drive units could be used, at lower operating costs. Therefore, tentatively pick a chain with rollers to run on the existing trough. Also tentatively figure on using the available 10" x 27" steel flights and attachment wings. The basic conveyor cross section might become a two-chain conveyor with scraper flights connected between the chains as shown in the following sketch.

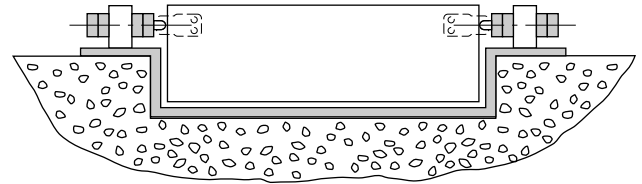

The unit becomes a scraper flight conveyor, similar to that indicated as a basic type of conveyor.

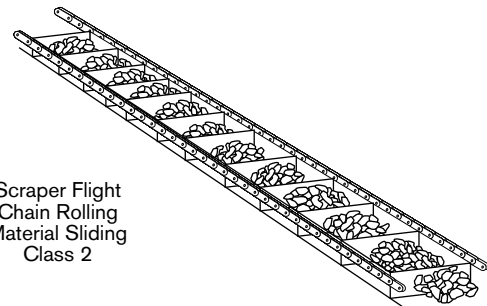

Step 2. Estimate Total Chain Pull

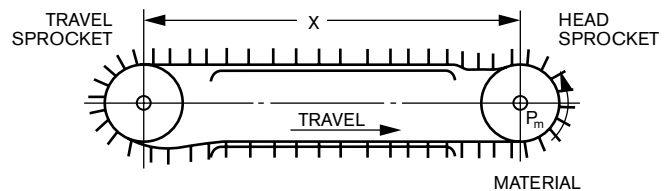

$$P_m = X (2f_1W + f_2M + \frac{h^2}{c}) + MY$$

Where:

- P_m = Maximum chain pull (Lbs.)
- X = Conveyor centers (100 Ft.)
- f_1 = Coefficient of friction – chain rolling on runway
- $f_1 = \frac{f_r d_a}{d_r}$ (See Table, page 123)
- $f_1 = 0.20$ (This factor will range from 0.10 to 0.20, depending upon the chain roller-bushing proportions. Since the chain pull is only being estimated at this point, use the highest range 0.20 in the first calculation.)
- M = Weight of material handled per foot of conveyor
- $M = \frac{TPH \times 33.3}{S} = \frac{170 \times 33.3}{100} = 56.6 \text{ Lbs./Ft.}$
- W = Weight per foot of moving conveyor parts
- S = Conveyor speed (feet/minute)

■ DESIGN AND SELECTION

CONVEYOR CHAIN SELECTION PROCEDURES – (Cont'd.)

Since the weight of the chain and attachment links has not yet been determined, use the empirical factor given on page 123 to establish chain weight.

$$W = .0015 \times 56.6 \text{ Lbs./Ft.} \times 100 \text{ Ft.} = 8.49 \text{ Lbs./Ft.}$$

Add to this the weight of the flights.

(There are approximately 100 flights available; assume a flight spacing of every 2 feet)

$$10 \text{ Lbs./ Flight} \times 1 \text{ Flight}/2 \text{ Ft.} = 5 \text{ Lbs./Ft.}$$

$$W = 8.49 \text{ Lbs./Ft.} + 5 \text{ Lbs./Ft.} = 13.49 \text{ Lbs./Ft.}$$

f_2 = Coefficient of friction of material

f_2 = 0.50 (Material friction factor table, page 123)

h = Height of material (see sketch of trough)

h = 6 inches

c = Trough side friction factor

c = 21 (Material friction factor table, page 123)

y = Vertical rise = 0 (Horizontal Conveyor)

Substitute Values in Formula:

$$P_m = X (2f_1W + f_2M + \frac{h_2}{c}) + MY$$

$$= 100 [2 (.20)(13.49) + .50 (56.6) + \frac{6^2}{21}] + 56.6 \times 0$$

$$= 100 (5.4 + 28.3 + 1.7)$$

$$P_m = 3540 \text{ Lbs.}$$

Step 3. Determine Design Working Load

Design W.L. = P_m x Service Factor x

Speed Factor x $\frac{1.2}{\text{No. of Strands}}$

$$= 3540 \times 1.2 \times 1.0 \times \frac{1.2}{2}$$

$$= 2545 \text{ Lbs.}$$

The Service Factor was picked from the table on page 153 for uniform loading since the conveyor is being fed from a hopper. A factor of 1.2 was selected because the conveyor will be in operation for more than 10 hours per day.

The speed factor was picked for a 12 tooth sprocket, although final sprocket selection has not been made. As indicated in the drive chain selection section (pages 94-95), a 12 tooth sprocket is a good first choice.

Step 4. Make Tentative Chain Selection

Refer to the chain selection chart and note that an engineered steel roller type chain is recommended for a Class 2 Conveyor.

Refer to pages 10-15 of the chain listing section and note that these chains all have rollers. For the conveyor arrangement tentatively selected, a Style “R” chain, whose rollers are larger than the sidebars, should be used. As indicated in the selection procedure, Step 4-g. (Page 125), a 4- to 6-inch pitch chain is good first choice. Also, from the calculation of Design Working Load, a chain having a working load rating of 2548 pounds or greater will be required.

Checking the chain listings, you will note a number of Style “R” chains in the desired pitch range. SR196 would be selected as the chain that most closely matches the desired working load. Chains such as 2188 and 1604 have working loads substantially higher and would not be economical choices. SR196 would be the tentative selection.

Step 5. Make Tentative Selection of Attachment Links

From the basic conveyor arrangement decided upon, an attachment lug which projects on one side of the chain only is required. Also, it is desired to select an attachment link to which the available flight wings can be adapted, if possible. This suggests a single-attachment lug such as the “A” attachment. The A1 (single hole) attachment is available for the SR196 Chain. Make this the tentative selection.

Step 6. Verify Chain Selection & Recheck Design Working Load

The exact chain and attachment link weight/ft. can now be used to calculate the Design Working Load. Also, the chain roller and bushing diameters can be used to determine the chain friction factor (f_1).

Chain Weight

$$\text{SR196 Plain Chain} = 5.0 \text{ Lbs./Ft.}$$

$$\text{SR196 A1 Attachment Link} = 6.6 \text{ Lbs./Ft.}$$

The weight per foot for the attachment link is based on a link interspersed every pitch. For the conveyor arrangement to be used, an attachment link will be required every 2 feet, or every 4th pitch (6 inch pitch chain).

$$3 \text{ plain links at } 5.0 \text{ Lbs./Ft.} = 15.0 \text{ Lbs.}$$

$$1 \text{ Attachment link at } 6.6 \text{ Lbs./Ft.} = \frac{6.6 \text{ Lbs.}}{21.6 \text{ Lbs.}}$$

$$21.6 \div 4 = 5.4 \text{ Lbs./Ft.}$$

$$\text{SR196 A1 every 4th link} = 5.4 \text{ Lbs./Ft.}$$

$$2 \text{ strands of chain} \times 5.4 \text{ Lbs./Ft.} = 10.8 \text{ Lbs./Ft.}$$

$$\text{Flight Weight} = \frac{5.0 \text{ Lbs./Ft.}}{15.8 \text{ Lbs./Ft.}}$$

$$15.8 \text{ Lbs./Ft.} = W = \text{Total weight of moving conveyor parts.}$$

DESIGN AND SELECTION

Chain Friction Factors

$$f_1 = f_r \frac{d_a}{d_r}$$

$f_r = 0.4$ (from table, page 154 for steel roller)

$d_a =$ Bushing diameter ($5/8$ " from chain listing, page 11)

$d_r =$ Roller O.D. (2" from chain listing, page 11)

$$f_1 = \left[\frac{0.4 (5/8)}{2} \right]$$

$$f_1 = 0.125$$

Use the final values of chain weight (W) and chain factor (f_1) in the chain pull formula

Use the same values for all other factors as in Step 2.

$$P_m = X \left(2f_1W + f_2M + \frac{h^2}{c} \right) + MY$$

$$= 100 \left[(2 \times .125 \times 15.8) + (.50 \times 56.6) + \frac{6^2}{21} \right] + (56.6 \times 0)$$

$$= 100 [(3.95) + (28.3) + (1.7)]$$

$P_m = 3395$ Lbs. total conveyor chain pull

Design Working Load = $P_m \times$ Service Factor \times Speed Factor $\times \frac{1.2}{\text{No. of Strands}}$

$$\text{Design W.L.} = 3395 \times 1.2 \times 1.0 \times \frac{1.2}{2}$$

$$= 2444 \text{ Lbs. chain pull per strand}$$

Since the final design working load of 2444 pounds does not exceed the maximum recommended working load of 2600 as given in the chain specifications (pages 11), the SR196 chain selection is acceptable.

ELEVATOR CHAIN PULL CALCULATION PROCEDURE

Bucket Elevator Formulas

To Determine Chain Pull (P_m):

$$P_m = 0.5 P_t + MKD + Y (M + W)$$

Knowing the chain pull, determine the design working load and select chain service and speed factors found on page 126.

To Determine Horsepower (HP):

$$HP = \frac{1.15 (S) (MDK + MY)}{33000}$$

Where: 33000

M = Weight of material handled per foot of elevator (lb./ft.)

M = Mat'l. Density (Lb./Ft.³) \times Bucket Cap. (Ft.³)

Bucket Spacing (Ft.)

W = Weight of chain and buckets per foot of elevator (lbs./ft.)

$$W = \frac{\left(\frac{\text{Attach. Spacing}}{\text{in Pitches} - 1} \right) \times \left(\frac{\text{Wt. of plain chain}}{\text{(lbs./ft.)}} \right) + \left(\frac{\text{Wt. of attach. chain}}{\text{(lbs./ft.)}} \right)}{\text{attachment spacing in pitches}}$$

$$+ \frac{\text{Wt. of a bucket (lbs.)}}{\text{bucket spacing (ft.)}}$$

$P_t =$ Take Up Force (Lbs.)

$P_1 = 1/2$ of $P_t + WY$

D = Footshaft sprocket pitch diameter (feet)

K = digging factor (10 for centrifugal, 6 for continuous)

Y = Elevator center distance (feet)

S = Elevator speed (feet/minute)

$$\text{TPH} = \text{Tons/Hour} = \frac{.75 (S) (M)}{33.3}$$

$$\text{CFH} = \frac{\text{TPH} \times (2000)}{\text{Mat'l Density (lbs./ft.³)}}$$

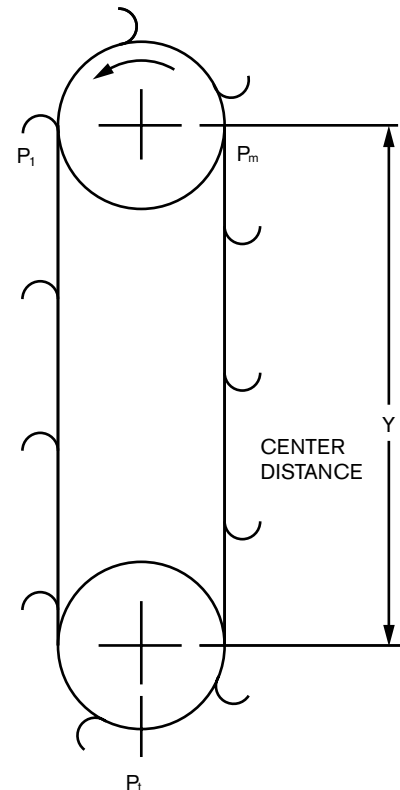

■ DESIGN AND SELECTION

APPLICATIONS BEYOND SCOPE OF CATALOG SELECTION PROCEDURES

Data Required for Selection

The selection procedures in this catalog were intended to cover the majority of conveyor, elevator and drive applications. However, some installations involve conditions or applications which require special

consideration in the selection process. The items listed below will aid in obtaining selection assistance. The items on this page are basic considerations which are necessary, if known, to insure selection of components best suited to the application.

General Information

1. Answer Required by (date): _____
2. Product: Chain Sprockets Other
3. Application: New Installation Replacement Component
4. Equipment Operating Time ___ Hours/Day; ___ Days/Week

Drives

1. Horsepower: Maximum ___ ; Percent of operating time at or above 75% Maximum Horsepower _____
2. RPM DriveR _____ DriveN _____ ; Ratio _____ Permissible Variation + _____ - _____
3. Center Distance _____
 Fixed Adjustable Permissible Variation \pm _____
4. Layout: Please provide sketch. Show Centers, DriveR, Direction of Rotation and Relation to Horizontal.

Conveyor and Elevator Components

1. Type: Elevator Bulk Material Conveyor Unit Handling Conveyor
2. Chain Speed: _____ Feet/Minute
3. Material Handled:
(a) If Bulk:
Characteristics: Dry Wet Sticky
Lump Size: _____ Inches (Maximum)
Quantity: _____ Tons/Hour;
_____ Cubic Feet/Hour
Density: _____ Lbs./Cubic Foot
If material density is not known, refer to material properties table on pages 173 and 174.
(b) If Units:
Quantity: _____ Units/Hour
Size: _____ x _____ x _____
Spacing: Random Regular
Weight: _____ Lbs. (each) _____ Lbs. (per foot of conveyor)
Total weight on conveyor at one time: _____ Lbs. (Max.)
4. Loading (in Cubic Feet/Hour or Units/Hour):
Normal _____ Peak _____
Percent of Time at Peak _____
5. Layout: Sketch showing centers, inclines, distance between chains, special attachments.

General

1. Desired Equipment Life: _____ Hours/Years
2. Environment
(a) Temperature: Surrounding _____ °F
Component _____ °F
If Cycling, Time at Temperature _____
(b) Abrasion: Material _____
Particle Size _____ Abrasiveness _____
(Refer to tables on pages 143-144).
(c) Corrosion: Material _____
Corrosiveness _____
(d) Lubrication: Lubricant _____
How Applied _____

Conveyor and Elevator

1. Sprockets (or Traction Wheels) – No. of Teeth (or Outside Diameter):
Head _____ Tail _____
2. Shaft Size: Head _____ Tail _____
3. Chain Attachments: Type _____ Spacing _____
4. Weight of Flights or Slats _____
5. Takeup Type: Screw Gravity – Weight
6. Elevator Buckets: Style _____
Size _____ x _____ x _____

Drives

1. Shaft Diameters: DriveR _____ DriveN _____
2. Application Description: _____

3. Peak Load Factor _____
Ratio of peak tension to mean tension while maximum horsepower is being transmitted.

■ DESIGN AND SELECTION

POLYMERIC CHAINS AND ACCESSORIES – APPLICATION INFORMATION

Materials

Standard Materials

Chain links are made from an acetal thermoplastic which offers several advantages over steel and stainless steel chains. The coefficient of friction for acetal is lower than either steel chains, reducing the horsepower requirement for the conveyor and preventing product damage when the chain slides under products backed up at various points in the conveyor. Acetal chains also reduce noise in a conveying system.

Combined with a stainless steel pin, the chain will not rust and has good resistance to many chemicals.

Special Materials

For applications requiring special chain capabilities, a wide range of materials and processing treatments have been developed. Consult Rexnord for details. (See the listing below for frequently encountered requirements).

FDA/USDA Compliance

Chain materials used are in compliance with FDA regulations and guidelines for use in direct food contact. Also, the chain materials have been found chemically acceptable for direct food contact with meat or poultry products by the Product Safety Branch of USDA. Also, the chain designs have been found acceptable for direct contact with meat or poultry products by the Equipment Branch of the Facilities, Equipment and Sanitation Division of USDA.

Environmental Factors

Chemical Resistance

Rex® polymeric chains, sprockets and idlers have good resistance to hydrocarbons, most neutral organic and inorganic materials, and to weak acids and bases in a pH range from 4 to 10.

To prolong chain life in the above situations, it is recommended to:

1. Avoid high temperatures of questionable liquids and/or solids. The closer to room temperature, the better.
2. Clean the chain! Thorough and frequent cleanings can limit prolonged exposure to questionable liquids and/or solids, decreasing the damaging effects of chemical attack.

Temperature Range

The allowable temperature range for Rex polymeric chains is -40°F to +180°F.

Consult Rexnord Corp. for operation beyond these temperatures.

Abrasion Resistance

Care should be taken when operating Rex polymeric chains in abrasive environments. Of particular concern is abrasive particles embedded in wearstrips and sprockets. These particles, once embedded, can work like a file to wear away the chain.

Rex sprockets are manufactured from super tough urethane. This material was selected because it is harder than most other available non-metallic sprocket materials and resists particle embedding. UHMW sprockets are not recommended for any application where dirt or other abrasives are present.

Sprockets

Rex polymeric chains are designed specifically for applications where corrosion resistance is desired. The current line of polymeric sprockets compliments the product line by offering additional corrosion resistance components. There are, however, situations that require metallic sprockets.

If a decision is made to use steel or cast sprockets, it is imperative to carefully inspect the sprocket for any unusual burrs, ridges, or protrusions and remove them before they come in contact with the polymeric chain. Such abrasive components have the capability of severely reducing the expected service life of the chain.

Flammability

Rex polymeric material will burn and support combustion. Acetal thermoplastics will burn with a clear flame and little smoke. Care should be taken to keep chain and accessories away from heat sources. Do not weld around conveyors or machinery without taking care to protect polymeric materials.

Ultra-Violet (UV) Resistance

Exposure to ultra-violet light can degrade polymeric chain materials. UV stabilized materials are available for use in direct sunlight.

Wear Strips

Metal Wear Strips

Metal wear strips are harder than non-metallics and, in addition, can be heat treated or work hardened to increase hardness. They are, therefore, suited for applications where abrasive particles are present either from the environment or from the products carried. Abrasive particles are less likely to imbed in metal wear strips.

For non-corrosive environments, plain carbon steel, cold finished, is recommended. For corrosive environments, use stainless steel, one quarter temper minimum (25Rc) cold finish.

■ DESIGN AND SELECTION

POLYMERIC CHAINS AND ACCESSORIES – APPLICATION INFORMATION – (Cont'd)

Wear Strips –(Cont'd.)

Steel

Plain carbon, cold rolled steel is recommended. Surface finish should be 32-63 RMS. Use heat treatable grades where available and hardened to 25-30Rc. Surface lubricants used should have rust inhibitors added.

Stainless Steel

Cold rolled finish (32-63 RMS) is recommended. An austenitic grade offers the best corrosion resistance.

The softer annealed grades of austenitic stainless steel are **not recommended**. Interaction between the chain material and the soft stainless steel might develop. When this happens, the resulting wear debris consists almost entirely of finely divided stainless steel particles, nearly black in color, similar to molydisulfide or graphite. The wear of the stainless steel might be rapid while the thermoplastic chain by contrast exhibits only slight wear.

Therefore, one quarter temper minimum austenitic grade stainless is recommended. Martensitic stainless steels can also be use. They offer excellent wear resistance when heat treated to 25-35Rc, but they are not as corrosion resistant as austenitic.

Aluminum

Not recommended due to poor wear resistance.

Non-Metallic Wear Strips

Non-metallic wear strips have a lower coefficient of friction than metals. They are generally easier to install and remove and provide for quieter operation. Nylatron is the preferred material, especially for dry operation at high load or high speed conditions around corners. Ultra high molecular weight polyethylene is also recommended for all well lubricated applications and some dry applications.

Acetal

Not recommended for use with acetal chains. It is best not to run identical plastics together.

Nylatron

Nylatron (nylon with molydisulfide filler) is the preferred material for dry applications because of its low wear state and low friction. It is especially suited for dry operation on double flex chain corners.

Although nylatron is more stable in wet applications than most nylons, it will absorb moisture and expand. Therefore, room for expansion must be provided and fasteners must allow for movement.

Ultra High Molecular Weight Polyethylene (UHMWPE)

UHMW polyethylene (molecular weight of at least 1.0 million) is recommended for both dry and wet applications on straight runs. It is also recommended for all well lubricated corners and non-lubricated corners where chain load and speed are low. It is not recommended for dry operation on corners where the chain load or speed are high. It is also not recommended for operation in environments where particulate matter is present and can embed in the UHMW, subsequently wearing the chain.

UHMWP has a wear rate equivalent to nylon in non-lubricated applications. It is virtually unaffected by moisture and is more resistant to corrosive chemicals than nylon. It is not as rigid as cast nylon and may deflect when subjected to high loads from sideflexing chains.

Teflon

This material has perhaps the lowest coefficient of friction available in a plastic wear strip material. It is soft and tends to flow off the surface and is not practical as a wear strip material except in low load – low speed applications.

Lubricant Impregnated Wood

Suitable for dry applications where self-lubricating properties of the material are best utilized. Not recommended for abrasive conditions where particles may imbed in the surface and wear the chain.

Catenary Sag

Rex[®] polymeric chain conveyors should provide for proper amount of catenary sag to allow proper chain and sprocket interaction. Ample space should be provided for the catenary. If chain sag is excessive or increased due to wear, it should be adjusted to the proper amount of sag by removing links. If space does not permit catenary sag, consult Rexnord.

Rex polymeric chains should never be run tight. Attempting to operate the chain with too little catenary sag can result in excessively high chain tension, leading to rapid chain wear to chain breakage. For this reason, screw take-ups are not recommended.

DESIGN AND SELECTION

POLYMERIC CHAINS AND ACCESSORIES – APPLICATION INFORMATION – (Cont'd) General Chain Pull Calculations

Overhead Conveyors

$$\text{Chain pull} = \text{Moving Load} + \frac{\text{Lift Load}^{\text{①}}}{\text{CS}}$$

Where:

MTW = Moving Total Weight lbs: (Weight of all N348 Chain, Trolleys, Shackle Hangers, Carriers and Product Weight in the **entire** conveyor.)

f_i = Friction Factor (see table).
Select the Friction Factor indicated for your trolley wheel diameter.

Note: A large number of vertical bends and horizontal turns will create slightly higher friction (consult Rexnord).

TR = Total Rise: (this is the total of all vertical rises)
Example: three four-foot rises,
 $\text{TR} = 3 \times 4 = 12 \text{ ft.}$

BW = Product Weight lbs. (average weight product)

CS = Carrier Spacing (feet)

Friction Factor f_i

Operating Conditions	Ball Bearing Trolleys Wheel Diameter		
	2"	3"	4"
0° to 180°F (clean conditions)	.025	.020	.018

① The worst condition (uncompensated loaded inclines) should be used in determining Lift Load.

Well **lubricated** anti-friction wheel turns and ball bearing trolley wheels are recommended; sliding corners are not recommended.

Rated Allowable Chain Pull

The maximum recommended chain pull/working load of N348 chain is **700 pounds**; if this chain pull is exceeded, additional drives must be used.

For more detailed information on chain pull calculations, refer to CEMA standard No. 601 – 1995 entitled “Overhead Trolley Chain Conveyors.” It is available from Conveyor Equipment Manufacturers Association, 9384-D Forestwood Lane, Manassas,

VA 20110.

POLYMERIC CHAINS AND ACCESSORIES – MAINTENANCE INFORMATION

Installation

- When connecting or disconnecting chain:
 - Always lock out the equipment power switch before removing or installing chains.
 - Always use safety glasses to protect your eyes.
 - Support the chain to prevent uncontrolled movement of chain and parts.
 - Tools for assembly or disassembly should be in good condition and properly used.
 - Always sight the pin with the hole before driving it home.
- The chains operate open end forward!**
Generally, it is best to run offset chains with the open end leading. This arrangement provides the smoothest action during sprocket engagement and assures getting the longest service life out of the chain and sprockets.
When chains are operated in this way, the wear from joint articulation is restricted primarily to the bearing surface (pin or bar) which is best able to withstand wear. In addition, sprocket wear is minimized because the motion between the chain and sprocket teeth during engagement is reduced.
- Any unusual burrs, ridges, or protrusions in the conveyor system that could cut into and destroy the chain, sprockets, or idlers must be removed.**

Cleaning

In many applications rapid build-up of grease, dirt, grit, sand and spilled liquid can occur. This can result in:

- Soiling and damage to the conveyed product.
- Increased work demands for the chain and motor.
- Accelerated sprocket tooth wear.
- Conveyor pulsation and wear.
- Excessive chain wear on the flight and in the joint areas.
- Rapid wear of the wear strips.

Frequent cleaning of the chain and conveyor frame is advised. Such agents as steam, warm water, and soap are commonly used. Many times combined “cleaners/lubricants” are applied continuously. Strong caustic agents used with metal chains should not be used with plastic chains. Always rinse cleaning agents completely off of the chain and conveyor frame. When excessive amounts of liquids, broken glass or debris accumulate, cleaning will be required on a regular basis to remove these undesirable materials. It is advisable to have operating personnel keep brushes and cleaning solutions nearby to remove broken glass and excessive spillage.